

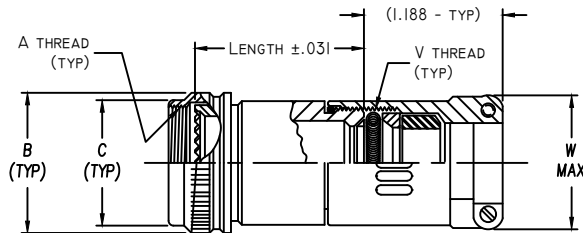


Table 2 - Cable Entry Data

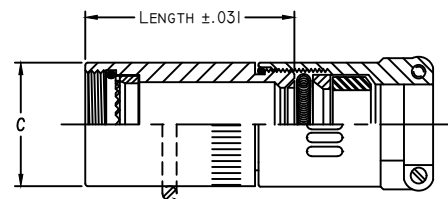
ENTRY ORDER NUMBER	CABLE RANGE		V	W
	MAX	MIN	UNIFIED THREAD	MAX DIM.
04	.250	.125	.625-24	.875
06	.375	.219	.750-20	1.000
08	.500	.344	.875-20	1.125
10	.625	.469	1.000-20	1.250
12	.750	.594	1.125-18	1.375
14	.875	.719	1.250-18	1.500
16	1.000	.844	1.375-18	1.625
18	1.125	.969	1.500-18	1.750
20	1.250	1.094	1.625-16	1.875

Table 3 - Length Code Data

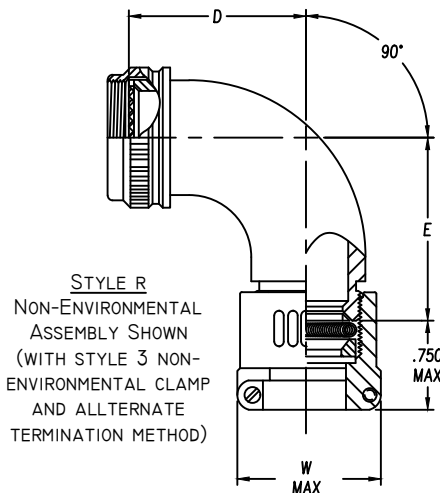
CONN CODE NUMBER	MIN ORDER LENGTH	MIN LENGTH CODE
18	1.250	05
19	1.750	07
21	1.250	05
30	1.500	06
32	1.750	09
40	1.250	05
41	1.250	05
47	1.250	05
51	1.250	05
54	1.250	05
61	1.500	06
76	1.250	05



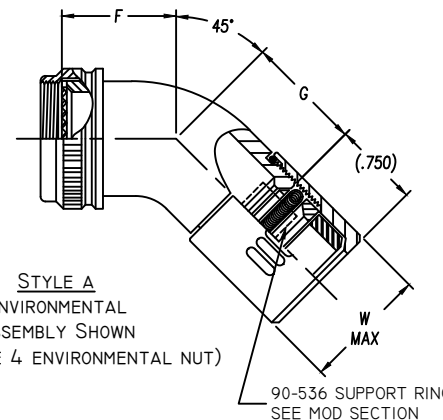
STYLE S
 (SHOWN WITH STYLE 3 ENVIRONMENTAL CLAMP)



STYLE B



STYLE R
 NON-ENVIRONMENTAL ASSEMBLY SHOWN (WITH STYLE 3 NON-ENVIRONMENTAL CLAMP AND ALLTERNATE TERMINATION METHOD)



STYLE A
 ENVIRONMENTAL ASSEMBLY SHOWN (WITH STYLE 4 ENVIRONMENTAL NUT)

ASSEMBLY PART NUMBER

TO ESTABLISH YOUR P/N, USE THE FOLLOWING EXAMPLE

E 41 15 S 23 08 9 B 06 51

FUNCTION DESIGNATOR
 E-EMI ADAPTER

CONNECTOR CODE NUMBER - TABLE 1

SERIES PART NUMBER

ADAPTER STYLE
 S = STRAIGHT SPIN COUPLING ADAPTER
 B = STRAIGHT BASIC ADAPTER
 R = 90° ADAPTER
 A = 45° ADAPTER

ACCESSORY ORDER NUMBER-TABLE 1

CABLE ENTRY ORDER NUMBER-TABLE 2

MOD CODE

PLATING CODE NUMBER-TABLE 4

LENGTH CODE NUMBER
 LENGTHS ARE CHOSEN IN 1/4" INCREMENTS (IE 08=2.00") SEE TABLE 3 FOR MINIMUM INSERT 00 FOR R & A STYLE ADAPTERS

GLAND & O'RING MATERIAL OPTION
 B - NEOPRENE & BUNA-N
 S - SILICONE
 N - NONE REQUIRED (NON ENVIROMENTAL)

CABLE STRAIN RELIEF - SEE TABLE V

Table 1 - Order Number Data

Accessory Order Number By Connector Code & Shell Size

ORDER NUMBER	18	21	32	40	41	54		64	61	76	A	B	C	(7) D	E	(7) F	G	ORDER NUMBER
	(4)		(2)	(3)							UNIFIED THREAD	MAX DIA.	MAX DIA.	±.125 DIM.	MAX DIM.	±.125 DIM.	MAX DIM.	
O1	8S (B)										.375-32	.750	.531					O1
O3	8S (A)										.438-27	.812	.594					O3
O4	8S (C)	8			8, 9					8	.438-28	.812	.594	1.125	1.438	.812	1.125	O4
O5						8 & 8S					.500-20	.875	.656					O5
O6	10S (-)								8, A		.500-28	.875	.656					O6
O7				9, A							M12 x 1.0	.719	.656					O7
O8	10SL (C)	10			10, 11			3		10	.562-24	.844	.719					O8
10	10SL(A,B), 12,12S(B,C)					10,10S,10SL			12		.625-24	1.000	.781	1.250	1.562	.875	1.188	10
11									10, B		.625-28	1.000	.781					11
12				11, B						12	M15 x 1.0	.844	.781					12
13	12 & 12S (A)	12			12, 13					12	.688-24	1.062	.844					13
15	14 & 14S (-)		12			12 & 12S	7	14			.750-20	1.125	.906	1.375	1.688	.938	1.250	15
16				13, C							M18 x 1.0	.969	.906					16
18		14			14, 15					14	.812-20	1.188	.969					18
19	16 & 16S (-)		14			14 & 14S	12	16			.875-20	1.250	1.031	1.500	1.812	1.000	1.312	19
20									14, D		.875-28	1.250	1.031					20
21				15, D							M22 x 1.0	1.094	1.031					21
23		16			16, 17					16	.938-20	1.312	1.094					23
24	18 (-)		16			16 & 16S	19	18			1.000-20	1.375	1.156	1.625	1.938	1.062	1.375	24
25									16, E		1.000-28	1.375	1.156					25
26				17, E							M25 x 1.0	1.219	1.156					26
28		18			18, 19	18	27			18	1.062-18	1.438	1.219					28
29	20 (-)		18					20			1.125-18	1.500	1.281					29
30	20 (R)										1.125-24	1.500	1.281	1.750	2.062	1.094	1.438	30
31									18, F		1.125-28	1.500	1.281					31
32				19, F							M28 x 1.0	1.344	1.281					32
34		20			20, 21	20	37			20	1.188-18	1.562	1.344					34
35	22 (-)		20					22			1.250-18	1.625	1.406	1.875	2.188	1.156	1.469	35
36									20, G		1.250-28	1.625	1.406					36
37				21, G							M31 x 1.0	1.469	1.406					37
39		22			22, 23	22				22	1.312-18	1.688	1.469					39
40	24 (-)		22					24			1.375-18	1.750	1.531	2.000	2.312	1.188	1.500	40
41									22, H		1.375-28	1.750	1.531					41
42				23, H							M34 x 1.0	1.594	1.531					42
44		24			24, 25	24				24	1.438-18	1.812	1.594					44
45							61				1.500-18	1.875	1.656					45
46									24, J		1.500-28	1.875	1.656	2.125	2.438	1.250	1.562	46
47				25, J							M37 x 1.0	1.719	1.656					47
48											1.562-18	1.938	1.719					48
49	28 (-)		24					28			1.625-18	2.000	1.781	2.375	2.688	1.344	1.688	49
51						28					1.750-18	2.125	1.906					51
52	32 (B,C)		28					32			1.875-16	2.250	2.031					52
53	32 (A,R)										1.906-18	2.281	2.062	2.625	2.938	1.438	1.750	53
54						32					2.000-18	2.375	2.156					54
55	36 (B)		32					36			2.062-16	2.469	2.219					55
56	36 (R)										2.062-24	2.469	2.219					56
57	36 (C)										2.125-16	2.500	2.281	2.875	3.188	1.562	1.875	57
58	36 (A)										2.125-18	2.500	2.281					58
59						36					2.250-16	2.625	2.406					59
60	40 (B)		36					40			2.312-16	2.719	2.469					60
61	40 (A,C)										2.375-16	2.750	2.531	3.125	3.438	1.688	2.000	61
62						40					2.500-16	2.875	2.656					62

NOTES: UNLESS OTHERWISE SPECIFIED.

1 THREADS ARE RIGHT HAND IN ACCORDANCE WITH FED-STD-H28, CLASS 2B.

(2) THREADS NOTED ARE LEFT HAND, CLASS 2B.

(3) THREADS NOTED ARE ISO METRIC, CLASS 6H.

(4) CODE 18 SHELL SIZES ARE FOLLOWED IN PARENTHESIS BY CONNECTOR MFR CODE. SEE CONNECTOR CODE 18 CHART AT RIGHT & EXAMPLE PART NUMBER FOR DETAILS.

5 TABLE 1 LISTS THE MOST USED CONNECTOR CODES. SEE SECTION 11 FOR OTHER CODES AVAILABLE AND COMPLETE CONNECTOR PART NUMBER CROSS REFERENCE.

(6) SEE SUPPORT DATA SECTION FOR PLATING AND MODIFICATION CODE OPTIONS.

(7) ADD .25 TO "D" & "F" FOR CONNECTOR CODES 30, 32 & 61.

(8) SEE SUPPORT DATA SECTION FOR TABLE V & AVAILABLE STYLES

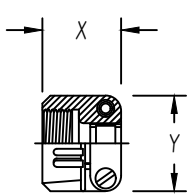
(4) Connector Code 18 Chart

CONNECTOR CODE	CONNECTOR MANUFACTURER (MS3100, MS3101, MS3106 & MS3107)
A	AMPHENOL, CLASS A
B	BENDIX, CLASS A, E & R
C	CANNON, CLASS A, E & R
D	MFR. UNKNOWN, CLASS A, E & R
R	AMPHENOL, CLASS R
-	MFR. CODE NOT REQUIRED

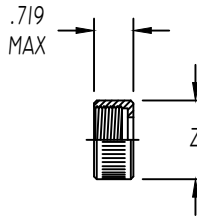


Table 2 - Environmental / Non-Environmental Cable Entry Data

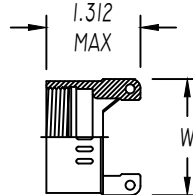
ENTRY ORDER NUMBER	ENVIRONMENTAL		NON ENVIRONMENTAL		V UNIFIED THREAD	R MAX DIM.	S MAX DIM.	T MAX DIM.	U MAX DIM.	W MAX DIM.	X MAX DIM.	Y MAX DIM.	Z MAX DIA.
	GLAND	RANGE	CABLE	RANGE									
	MAX	MIN	MAX	MIN									
03	.250	.156	.250	.156	.500-28	N / A	.812	1.375	.812	N / A	.844	.781	.656
04	.312	.188	.312	.188	.625-24	1.031	.937	1.375	.937	.875	.844	.906	.781
06	.438	.281	.438	.281	.750-20	1.031	1.062	1.375	1.062	1.000	.906	1.094	.906
08	.562	.375	.562	.344	.875-20	1.031	1.188	1.375	1.188	1.125	.969	1.188	1.031
10	.625	.500	.625	.375	1.000-20	1.094	1.312	1.437	1.312	1.250	.969	1.281	1.156
12	.750	.500	.750	.438	1.188-18	1.219	1.562	1.437	1.562	1.375	.969	1.500	1.344
14	.875	.750	.875	.719	1.250-18	N / A	N / A	N / A	N / A	1.500	N / A	N / A	N / A
16	1.000	.844	1.000	.781	1.438-18	1.219	1.750	1.562	1.750	1.625	1.062	1.719	1.594
20	1.250	.938	1.250	.750	1.750-18	1.344	2.250	1.812	2.250	1.750	1.125	2.062	1.906
24	1.375	1.000	1.375	.781	2.000-18	N / A	2.375	2.062	2.375	N / A	1.188	2.312	2.156
28	1.625	1.250	1.625	.969	2.250-16	N / A	2.625	2.062	2.625	N / A	1.719	2.719	2.406
32	1.875	1.500	1.875	1.125	2.500-16	N / A	2.812	2.188	2.812	N / A	1.781	2.969	2.656



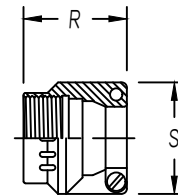
STYLE 1
 AS85049/41A CLAMP
 (MS 3057**A)



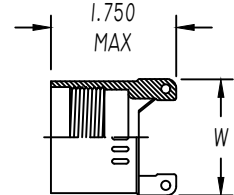
STYLE 2
 NUT



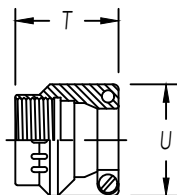
STYLE 3
 NON-ENVIRONMENTAL



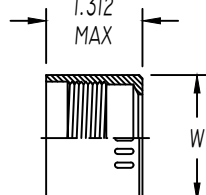
STYLE 3
 NUT ENVIRONMENTAL
 (AS85049/1)
 (MS 3057-**B)



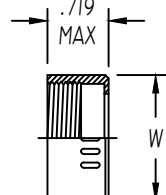
STYLE 3
 ENVIRONMENTAL



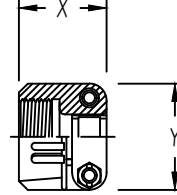
STYLE 4
 STRAIN RELIEF ENVIRONMENTAL
 (AS85049/2)
 (MS 3057-**C)



STYLE 4
 ENVIRONMENTAL



STYLE 4
 NON-ENVIRONMENTAL



STYLE 9
 STRAIN-RELIEF CLAMP WITH TELESCOPING SCREWS

NOTES: UNLESS OTHERWISE SPECIFIED

AVAILABLE ONLY ON: A**01, A**30, E**01, E**03, E**04, E**05, E**07, E**21, E**30, & E**33

AVAILABLE ONLY ON: E**15, E**17, E**38, E**40, & E**41

3. CONSULT FACTORY FOR SIZES AND INFORMATION NOT LISTED