



ELECTRO ADAPTER INC.
 CHATSWORTH, CALIFORNIA, USA 91311
 PHONE (818) 998-1198
 FAX (818) 709-5773

SECTION 3 - RECTANGULAR ADAPTER
EMI / RFI , BAND TERMINATION ,
STRAIGHT , 90° SIDE ENTRY
MIL - DTL - 24308 , D-SUB

901-820

SHEET 1 OF 1

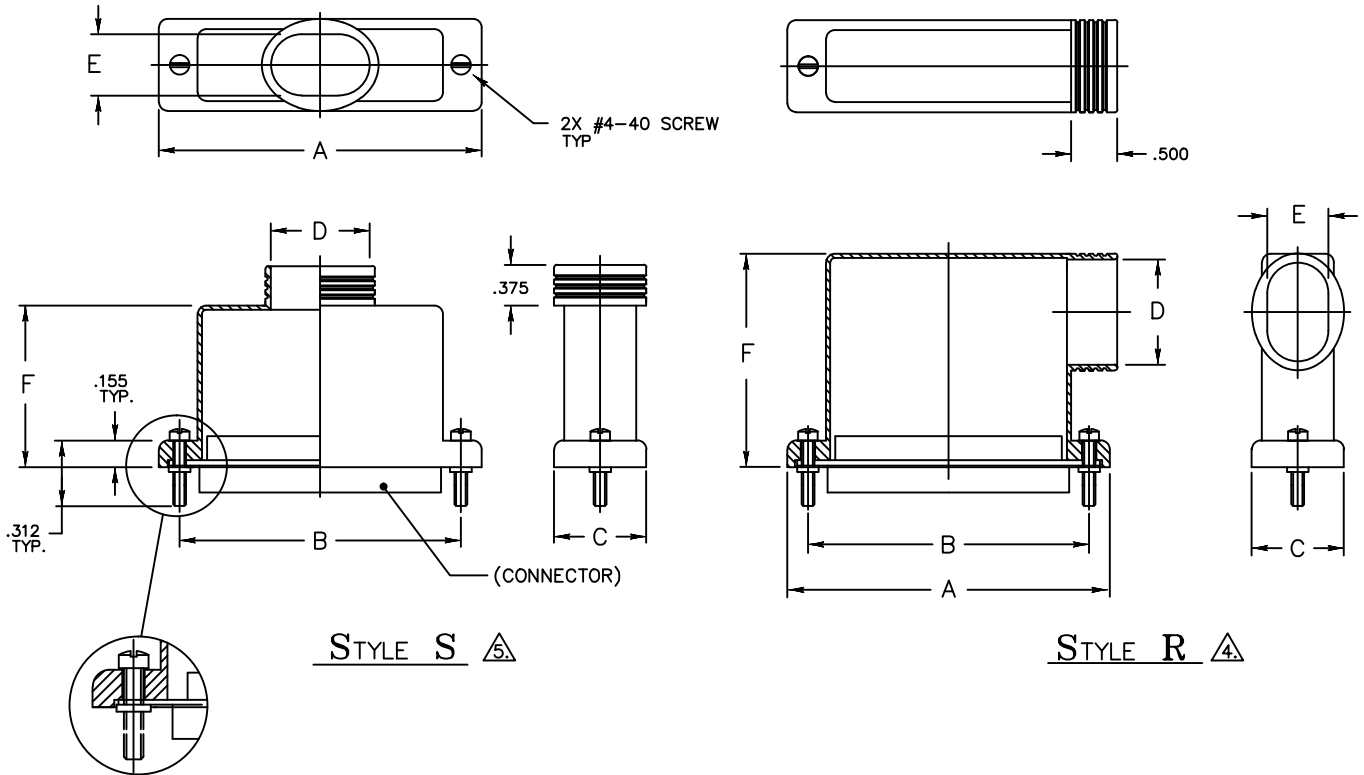

STYLE S

STYLE R

NYLON WASHER
 SEE PART NUMBER

Example Part Number

901 - 820 S 25 1 56 *

BASIC ADAPTER NO.

ADAPTER STYLE
 S = STRAIGHT ADAPTER
 R = 90° ADAPTER

JACKSCREW TYPE
 F = 2 MALE FILLISTER
 H = 2 MALE HEX SOCKET
 J = 2 FEMALE JACKPOST
 OMIT IF JACKSCREWS & WASHERS NOT REQUIRED

PLATING CODE NUMBER
 CODE 56 - ELECTROLESS NICKEL, PER SAE
 AMS-C-26074F WITH IRIDITE
 CONVERSION.
 FOR ADDITIONAL FINISH, SEE CATALOG TABLE 4.

CONNECTOR SHELL SIZE					
SHELL SIZE	A ±.030	B ±.005	C ±.030	D ±.010	E ±.030
9	1.366	.984	.640	.430	.437
15	1.694	1.312	.640	.500	.500
25	2.241	1.852	.640	.687	.437
37	2.882	2.500	.640	.800	.437
50	2.778	2.406	.750	.900	.552
104	2.882	2.500	.812	.900	.552

HEIGHT CODE	
HEIGHT CODE	F ±.03
BLANK	.78
1	1.25
2	1.50
3	1.75
4	2.00
5	2.25
6	1.00

- NOTES: UNLESS OTHERWISE SPECIFIED
- ASSEMBLY IDENTIFICATION PER MIL-STD-1285
 - MATERIAL: BACKSHELL - ALUMINUM ALLOY
 HARDWARE - STAINLESS STEEL
 GASKET - EMI ALUMINUM WEAVE,
 NEOPRENE IMPREGNATED
- SCREWS ARE CAPTIVATED WITH NYLON WASHERS
 NOT AVAILABLE ON SHELL SIZE 37 OR 50 STYLE R ADAPTERS
 BLANK HEIGHT CODE AVAILABLE WITH STYLE S ONLY



STANDARD FINISHES

PLATING CODE	FINISH	SPECIFICATION	ACCESSORY MATERIAL	CORROSION RESISTANCE (HRS)	ROHS COMPLIANT
0 3	CADIUM PLATE, OLIVE DRAB	SAE AMS-QQ-P-416, TYPE II, CLASS 3	ALUMINUM	96	NO
1 0	PASSIVATE	SAE AMS-QQ-P-35, (AS85049 CODE S)	STAINLESS STEEL	1000	YES
1 2	ZINC NICKEL, BLACK	ASTM B841	ALUMINUM	500	YES
1 3	ZINC COBALT, OLIVE DRAB	ASTM B840-99	ALUMINUM	96	NO
1 4	ZINC COBALT, BLACK	ASTM B840-99	ALUMINUM	96	NO
2 1	IRIDITE, 14-2, GOLD	IRIDITE, NUMBER 14-2 PER MIL-DTL-5541 CL 3	ALUMINUM	96	NO
3 4	ANODIZE, BLACK	MIL-A-8625, TYPE II, CL 3 (AS85049 CODE A)	ALUMINUM	1000	YES
3 5	ANODIZE ,GREY	MIL-A-8625, TYPE II, CLASS 2	ALUMINUM	500	YES
4 4	ANODIZE, HARD, BLACK	MIL-A-8625, TYPE II, CLASS 2	ALUMINUM	500	YES
4 5	ANODIZE, HARD, GREY	MIL-A-8625, TYPE II, CLASS 2	ALUMINUM	1000	YES
4 8	ELECTROLESS NICKEL	AMS-2404F, CLASS 4, GRADE B	STAINLESS STEEL	48	NO
5 1	ELECTROLESS NICKEL	AMS-2404F, CLASS 4, GRADE B	ALUMINUM	48	NO
5 5	CADIUM PLATE, OLIVE DRAB, OVER ELECTROLESS NICKEL	SAE AMS-QQ-P-416, TYPE II, CLASS 3, OVER ELECTROLESS NICKEL, PER AMS-2404F (AS85049 CODE W)	ALUMINUM	1000	NO
5 6	ELECTROLESS NICKEL	AMS-2404F, CLASS 4, GRADE A	ALUMINUM	96	NO
5 6 R	ELECTROLESS NICKEL	AMS-2404F, CLASS 4, GRADE A	ALUMINUM	48	YES
5 7	ELECTROLESS NICKEL	AMS-2404F, CLASS 4, GRADE A (AS85049 CODE N)	ALUMINUM	96	NO
64	CADIUM PLATE, OLIVE DRAB, OVER ELECTROLESS NICKEL	SAE AMS-QQ-P-416, TYPE II, CLASS 3, OVER ELECTROLESS NICKEL, PER AMS-2404F (SELECTIVE PLATING REF AS85049 CODE P)	ALUMINUM	1000	NO
85	PASSIVATED	SAE AMS-QQ-P-35	316 SST	1000	YES
87	BEAD BLASTED	N/A	NI. ALUM. BRONZE	1000	YES

NOTES: UNLESS OTHERWISE SPECIFIED

1. CORROSION RESISTANCE IS SPECIFIED FOR SALT SPRAY IN ACCORDANCE WITH AS85049
- CONSULT FACTORY FOR OTHER FINISHES
- FINISHES ARE APPLICABLE TO THE CONNECTOR ACCESSORIES ONLY AND EXCLUDE FASTENERS AND OTHER HARDWARE
4. EMI/RFI ACCESSORIES ARE SUPPLIED WITH CONDUCTIVE FINISHES ONLY
5. ANODIZE NOT SUITABLE FOR EMI SHIELDING OR GROUNDING APPLICATIONS
6. ALL THE CONDUCTIVE FINISHES USED ON ALUMINUM CAN ALSO BE USED ON BRASS (CONSULT FACTORY)
- CADMIUM/NICKEL INTERFACE SHALL BE COATED WITH POLYSULFIDE SEALANT (REF FIGURE 2 BELOW)

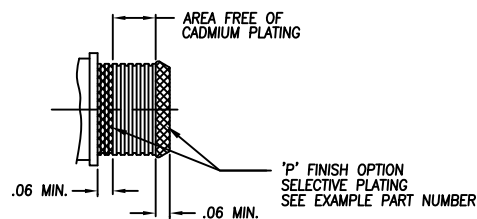

FIGURE 2



STANDARD MATERIALS

COMPONENT	MATERIAL	SPECIFICATION
MACHINED COMPONENTS	ALUMINUM STAINLESS STEEL (300 SERIES) BRASS NICKEL ALUMINUM BRONZE	ASTM B221, ASTM B211 (MFG OPTION) AMS-QQ-S-763, QQ-S-764 (MFG OPTION) QQ-B-626 ASTMB150 (AMS4640)
DIE CAST COMPONENTS	ALUMINUM	ASTM B 85
FASTENERS AND HARDWARE	STAINLESS STEEL (300 SERIES) STEEL BRASS	AMS-QQ-S-763 SAE20, QQ-S-634, QQ-S-637 QQ-B-626
ELASTOMERIC SEALS	SILICONE BUNA-N NEOPRENE	ZZ-R-765B, MIL-R-25988 AMS-3209 MIL-R-3065

NOTES: UNLESS OTHERWISE SPECIFIED

1. THE SPECIFIED MATERIALS ARE STANDARD FOR THE MAJORITY OF CONNECTOR ACCESSORIES
2. CONSULT FACTORY FOR OTHER MATERIALS
3. FOR DOCUMENTS LISTED WITHIN THIS CATALOG WITH OUT A TOLERANCE SHOWN SHALL HAVE TOLERANCES AS FALLOWED:
 - .X = ±.2
 - .XX = ±.12
 - .XXX = ± .062
 - X° = ±10°