



**ELECTRO ADAPTER, INC.**

CHATSWORTH, CALIFORNIA, USA 91311  
PHONE: (818) 998-1198  
FAX: (818) 709-5773

SHIELD ADAPTER FOR MIL-DTL-5015,  
MIL-DTL-26482 SERIES 2, MIL-DTL-83723  
SERIES I & III, MIL-C-81703 SERIES III

SPECIFICATION CONTROL DRAWING

**901-424**

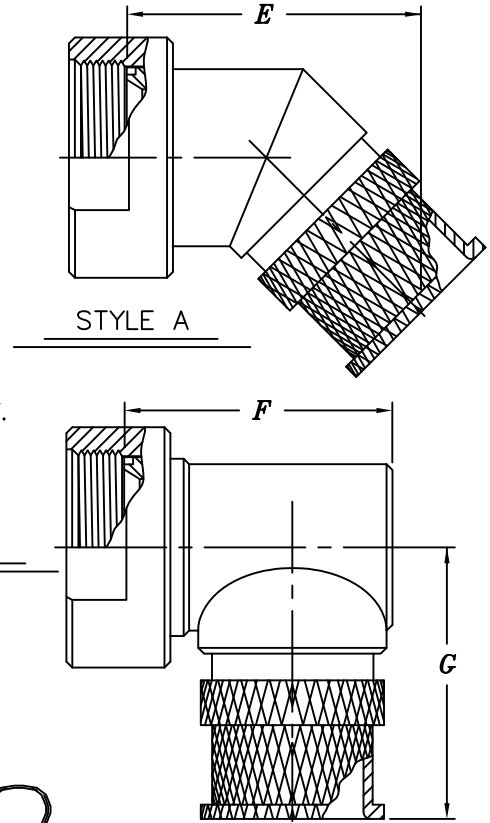
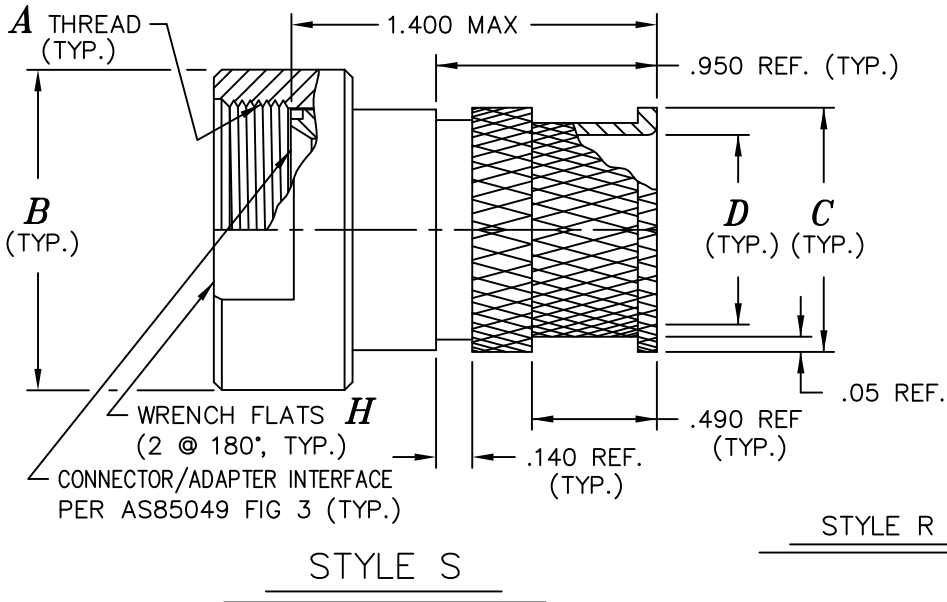

*Example Part Number*

**901-424S210**

BASIC ADAPTER NUMBER

ADAPTER STYLE  
 STYLE S = STRAIGHT ADAPTER  
 STYLE A = 45° ADAPTER  
 STYLE R = 90° ADAPTER

PLATING CODE NUMBER  
 10 = PASSIVATE, PER SAE-AMS-QQ-P-35  
 12 = BLACK, ZINC NICKEL, TYPE II, CLASS 2  
 55 = CADMIUM, OLIVE DRAB, PER SAE AMS-QQ-P-416, TYPE II, CLASS 3,  
 OVER ELECTROLESS NICKEL PER AMS-C-26074, CLASS 3 OR 4, GRADE B  
 56 = ELECTROLESS NICKEL PER SAE AMS-2404F, CLASS 3 OR 4, GRADE A.  
 FOR ADDITIONAL FINISH OPTIONS, SEE CATALOG TABLE 4.

**NOTES:**

- ASSEMBLY IDENT. PER MIL-STD-1285.
- MATERIAL: COMPONENTS - ALUMINUM ALLOY, 300 SERIES STAINLESS STEEL.
- SEE DRAWING NUMBER 901-436 FOR SHIELD TERMINATION SPRING.

ADAPTER DATA								
ORDER NUMBER	A UNIFIED THD. CLASS 2B	B MAX. DIA.	C MAX. DIA.	D REF DIA.	E REF.	F REF.	G REF.	H ACROSS FLATS
1	.500-20	.78	.53	.25	1.57	.81	1.344	.625
2	.625-24	.91	.61	.31	1.59	.87	1.375	.750
3	.750-20	1.03	.78	.50	1.63	1.06	1.438	.875
4	.875-20	1.16	.84	.56	1.67	1.12	1.500	1.000
5	1.000-20	1.28	.96	.68	1.71	1.25	1.562	1.125
6	1.062-18	1.34	1.04	.75	1.77	1.31	1.594	1.188
7	1.188-18	1.47	1.22	.87	1.81	1.43	1.656	1.312
8	1.312-18	1.59	1.35	1.00	1.84	1.56	1.719	1.438
9	1.438-18	1.72	1.48	1.12	1.90	1.68	1.781	1.562