



ELECTRO ADAPTER, INC.
 CHATSWORTH, CALIFORNIA, USA 91311
 PHONE: (818) 998-1198
 FAX: (818) 709-5773
 WEB SITE: www.electro-adapter.com

EMP BAND ADAPTER

ENTRY SPECIFICATION SHEET *

SPECIFICATION CONTROL DRAWING

217

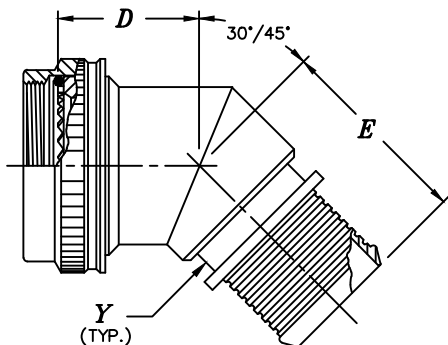

STYLE A, F OR G
SEE PART NUMBER

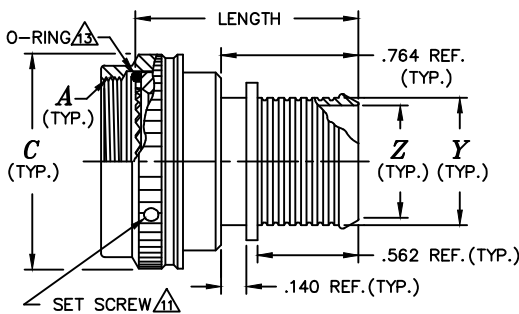

STYLE S

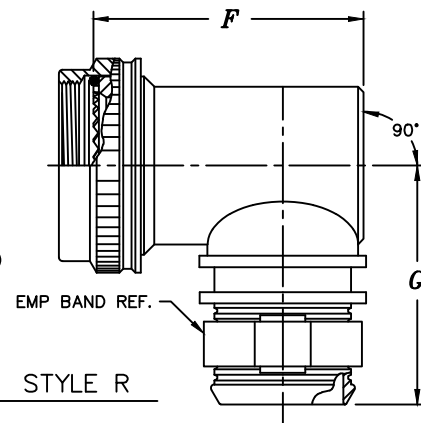

STYLE R

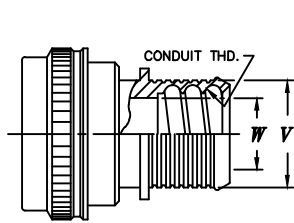

MODIFICATION C
(HELICAL CONDUIT THREAD)

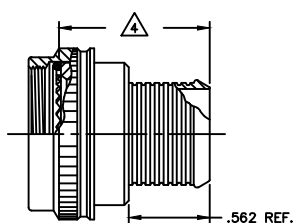

MODIFICATION Z
(LESS BOOT GROOVE)

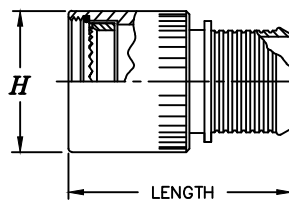

STYLE B

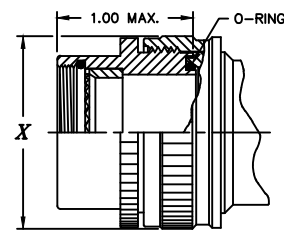

2 PIECE

Example Part Number

21741S161030855H

BASIC ADAPTER NUMBER

STYLE
 S = STRAIGHT F = 30°
 A = 45° G = 60°
 R = 90° B=BASIC

ORDER NO. PER TABLE II

MODIFICATION CODE
 S = SELF LOCKING ROUND COUPLING.
 Z = LESS BOOT GROOVE, OMIT FOR STANDARD BOOT GROOVE
 C = HELICAL CONDUIT THREAD

TABLE - CONNECTOR CODE

MILITARY SPECIFICATION	SERIES	CODE NO.
MIL-DTL-5015D	3100	1 8
MIL-DTL-83723	II	1 9
MIL-DTL-26482	1	2 1
MIL-DTL-26482	1 (07)	2 4
MIL-DTL-28840	-	3 0
MIL-DTL-22992	-	3 2
MIL-DTL-38999	III & IV	40
MIL-DTL-38999	I & II	41
LN 29729, PATT 615, PAN 6433-2,	-	47
MIL-DTL-26500	(ALUMINUM)	5 1
MIL-DTL-5015G	3400	54
MIL-C-81703	3	54
MIL-DTL-83723	I	54
MIL-DTL-26482	2	54
MIL-DTL-83723	III	54
NAS1599	-	54
MIL-C-81511	1, 2, 3 & 4	6 1
PATT 105, PATT 603, PATT 608	-	76

TABLE III - CABLE/HARNESS ENTRY DATA

ENTRY ORDER NO.	EMP BAND			HELICAL CONDUIT		
	Z +.010 -.020 DIA.	Y ±.015 DIA.	X MAX DIA.	CONDUIT THREAD SIZE	W REF. DIA.	V ±.015 DIA.
0 2	.125	.209	N/A	N/A	N/A	N/A
0 3	.188	.271	N/A	N/A	N/A	N/A
0 4	.250	.334	N/A	N/A	N/A	N/A
0 5	.312	.396	.734	0188	.188	.413
0 6	.375	.459	.734	0281	.281	.507
0 7	.438	.521	.858	0312	.312	.531
0 8	.500	.584	.858	0375	.375	.603
0 9	.562	.646	N/A	0438	.438	.664
1 0	.625	.709	1.112	0500	.500	.743
1 2	.750	.834	1.345	0625	.625	.863
1 4	.875	.959	1.345	N/A	N/A	N/A
1 6	1.000	1.084	1.594	0750	.750	1.023
1 8	1.125	1.209	1.594	0875	.875	1.166
1 9	1.188	1.209	1.594	N/A	N/A	N/A
2 0	1.250	1.334	1.969	1000	1.000	1.319
2 2	1.375	1.459	2.219	N/A	N/A	N/A
2 4	1.500	1.584	2.219	1250	1.250	1.632

PLATING CODE NUMBER

55 = CADMIUM, OLIVE DRAB, PER SAE-AMSQQ-P-416, TYPE II, CLASS 3, OVER ELECTROLESS NICKEL PER AMS-C-26074, CLASS 3 OR 4, GRADE B
 56 = ELECTROLESS NICKEL PER SAE-AMS-2404F, WITH IRIDITE CONVERSION
 FOR ADDITIONAL FINISH OPTIONS, SEE CATALOG TABLE 4.

LENGTH CODE NUMBER

SELECT LENGTH IN 1/4" INCREMENTS (ie; 08=2.00", 09=2.25", etc.)
 00 FOR 45° & 90° ADAPTERS (STYLES A & R)

MIN. AVAIL. LENGTH	CONNECTOR CODES (TABLE I)
1.250	18, 21, 40, 41, 47, 51, 52, 54, 55, 71
1.500	24, 30, 32, 61, 64

TERMINATION NUMBER

- 1 = ADAPTER ONLY
- 4 = ADAPTER w/ 1/4" EMP BAND (REF. 214L0002)
- 5 = ADAPTER w/ 1/4" EMP BAND AND SHRINK BOOT
- 6 = ADAPTER w/ 1/8" EMP BAND (ENTRY 13-24 CUSTOMER SUPPLIED)
- 7 = ADAPTER w/ 1/8" EMP BAND (ENTRY 13-24 CUSTOMER SUPPLIED)
- 8 = ADAPTER w/ 1/8" EMP BAND (REF. 214L0005)
- 9 = ADAPTER w/ 1/4" EMP BAND (A10086)

* THIS DOCUMENT INCOMPLETE WITHOUT "INTERFACE SPECIFICATION SHEET".

UNCONTROLLED COPY



TABLE II - CONNECTOR CODE 18
MIL-C-5015D, 3100 SERIES

ORDER NO.	SHELL SIZE	MFR. CODE △	A UNIFIED THD. CLASS 2B	C MAX. DIA.	D MAX.	E MAX. △	F MAX.	G MAX. △/△	BAND MAX. 1 PIECE ENTRY	MOD. C MAX. 1 PIECE ENTRY
08B	8S	B	.375-32	.719	.68	1.15	.94	1.28	0 4	0 5
08C	8S	C	.438-28	.719	.69	1.16	1.00	1.28	0 5	0 7
08A	8S	A	.438-27	.719	.69	1.16	1.00	1.28	0 5	0 7
08D	8S	D	△9	.719	.69	1.16	1.00	1.28	0 5	0 7
10-	10S	-	.500-28	.781	.70	1.17	1.06	1.31	0 6	0 8
11C	10SL	C	.562-24	.844	.72	1.19	1.13	1.34	0 7	0 9
11A	10SL	A	.625-24	.906	.73	1.20	1.19	1.38	0 8	1 0
11B	10SL	B	.625-24	.906	.73	1.20	1.19	1.38	0 8	1 0
11D	10SL	D	△9	.906	.73	1.20	1.19	1.38	0 8	1 0
12B	12,12S	B	.625-24	.906	.73	1.20	1.19	1.38	0 8	1 0
12C	12,12S	C	.625-24	.906	.73	1.20	1.19	1.38	0 8	1 0
12A	12,12S	A	.688-24	.969	.74	1.21	1.25	1.41	0 9	1 0
12D	12,12S	D	△9	.969	.74	1.21	1.25	1.41	0 9	1 0
14-	14,14S	-	.750-20	1.031	.76	1.23	1.31	1.44	1 0	1 2
16-	16,16S	-	.875-20	1.219	.78	1.25	1.44	1.53	1 2	1 6
18-	18	-	1.000-20	1.344	.79	1.26	1.50	1.59	1 3	1 6
20-	20	-	1.125-18	1.469	.83	1.30	1.69	1.66	1 6	2 0
20R	20	R	1.125-24	1.469	.83	1.30	1.69	1.66	1 6	2 0
20D	20	D	△9	1.469	.83	1.30	1.69	1.66	1 6	2 0
22-	22	-	1.250-18	1.594	.86	1.33	1.81	1.72	1 8	2 0
24-	24	-	1.375-18	1.719	.89	1.36	1.94	1.78	2 0	2 4
28-	28	-	1.625-18	1.969	.91	1.38	2.06	1.88	2 2	2 4
32B	32	B	1.875-16	2.219	.96	1.43	2.31	2.00	2 4	2 4
32C	32	C	1.875-16	2.219	.96	1.43	2.31	2.00	2 4	2 4
32A	32	A	1.906-18	2.219	.96	1.43	2.31	2.00	2 4	2 4
32R	32	R	1.906-18	2.219	.96	1.43	2.31	2.00	2 4	2 4
32D	32	D	△9	2.219	.96	1.43	2.31	2.00	2 4	2 4
36B	36	B	2.062-16	2.469	1.01	1.48	2.56	2.13	2 4	2 4
36R	36	R	2.062-20	2.469	1.01	1.48	2.56	2.13	2 4	2 4
36C	36	C	2.125-16	2.469	1.01	1.48	2.56	2.13	2 4	2 4
36A	36	A	2.125-18	2.469	1.01	1.48	2.56	2.13	2 4	2 4
36D	36	D	△9	2.469	1.01	1.48	2.56	2.13	2 4	2 4
40B	40	B	2.312-16	2.719	1.07	1.54	2.81	2.25	2 4	2 4
40A	40	A	2.375-16	2.719	1.07	1.54	2.81	2.25	2 4	2 4
40C	40	C	2.375-16	2.719	1.07	1.54	2.81	2.25	2 4	2 4
40D	40	D	△9	2.719	1.07	1.54	2.81	2.25	2 4	2 4
44A	44	A	2.625-16	2.969	1.12	1.59	3.06	2.38	2 4	2 4
44C	44	C	2.625-16	2.969	1.12	1.59	3.06	2.38	2 4	2 4
44D	44	D	△9	2.969	1.12	1.59	3.06	2.38	2 4	2 4
48C	48	C	2.812-18	3.219	1.17	1.64	3.31	2.50	2 4	2 4
48A	48	A	2.875-16	3.219	1.17	1.64	3.31	2.50	2 4	2 4
48D	48	D	△9	3.219	1.17	1.64	3.31	2.50	2 4	2 4

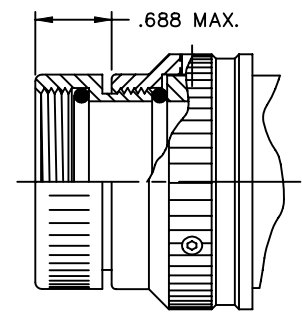

MFR. CODE D^{△9}△₁₂
 (CODE 18 ONLY)

- NOTES:
- ASSEMBLY IDENT. PER MIL-STD-130.
 - MATERIAL: COMPONENTS - ALUM. ALLOY
O-RING - SILICONE
 - △3 "2 PIECE" CONFIG. SUPPLIED WHEN CABLE ENTRY DIA. EXCEEDS CONN. INSERT DIA..
 - △4 DIMENSIONS INDICATED WILL BE .20" LESS WHEN ORDERED WITH MOD. CODE Z.
 - △5 FOR MULTIPLE MOD. CODES USE SEQUENCE SHOWN.
 - △6 FOR MODIFICATION C AND ENTRY 24, ADD .188" TO LENGTH SHOWN.
 - △9 ACCOMODATES ALL CONN. THD. SIZES.
 - △11 PROVIDED ON CONNECTOR CODES 18 AND 21 ONLY.
 - △12 A = AMPHENOL - CLASS A
B = BENDIX - CLASS A, E, & R
C = CANNON - CLASS A, E, & R
D = MFR. UNKNOWN - CLASS A, E, & R
R = AMPHENOL - CLASS R
- = MFR. CODE NOT REQUIRED
 - △13 NOT PROVIDED ON CONNECTOR CODES 36, 38, 54, & 55.
 - △14 FOR SHROUD INSTEAD OF O-RING USE CONNECTOR CODE 36.
 - △15 FOR SHROUD INSTEAD OF O-RING USE CONNECTOR CODE 38.
 - △16 FOR THRU TEETH AND SHROUD USE CONNECTOR CODE 55.
 - △17 FOR CODES 36 AND 38 SELF-LOCKING HEX COUPLING IS STANDARD. "H" MOD. IS SELF-LOCKING SQUARE COUPLING.

* THIS DOCUMENT INCOMPLETE WITHOUT "ENTRY SPECIFICATION SHEET".

UNLESS OTHERWISE SPECIFIED DIMENSIONS ARE IN INCHES	MATERIAL AND FINISH PER NOTES DO NOT SCALE DRAWING	TOLERANCES: .XX = ± .06 .XXX = ± .03 ANGLES = ± 2°	CAGE CODE 31461	0\CAT\4\ 217-18	DR RGW 07-05-90	CHK WS 07-05-90	APP	REV. D
--------------------------------------------------------	-------------------------------------------------------	----------------------------------------------------------	--------------------	--------------------	--------------------	--------------------	-----	-----------

UNCONTROLLED COPY



**TABLE II — CONNECTOR CODE 21
 MIL-C-26482, SERIES 1**

ORDER NO.	SHELL SIZE	<i>A</i> UNIFIED THD. CLASS 2B	<i>C</i> MAX. DIA.	<i>D</i> MAX.	<i>E</i> MAX. ⚠	<i>F</i> MAX.	<i>G</i> MAX. ⚠⚠	<i>H</i> MAX. DIA.	BAND MAX. 1 PIECE ENTRY	MOD. C MAX. 1 PIECE ENTRY
0 8	8	.438-28	.703	.62	1.16	1.00	1.28	.813	0 5	0 7
1 0	10	.562-24	.827	.63	1.17	1.06	1.34	.938	0 6	0 8
1 2	12	.688-24	.953	.66	1.20	1.19	1.41	1.125	0 8	1 0
1 4	14	.812-20	1.077	.69	1.23	1.31	1.47	1.250	1 0	1 2
1 6	16	.938-20	1.203	.71	1.25	1.44	1.53	1.375	1 2	1 6
1 8	18	1.062-18	1.327	.74	1.28	1.56	1.59	1.500	1 4	1 8
2 0	20	1.188-18	1.453	.76	1.30	1.69	1.66	1.625	1 6	2 0
2 2	22	1.312-18	1.577	.79	1.33	1.81	1.72	1.750	1 8	2 0
2 4	24	1.438-18	1.703	.82	1.36	1.94	1.78	1.875	2 0	2 4

NOTES:

1. ASSEMBLY IDENT. PER MIL-STD-130.
2. MATERIAL: COMPONENTS — ALUM. ALLOY
O’RING — SILICONE
- ⚠ "2 PIECE" CONFIG. SUPPLIED WHEN CABLE ENTRY DIA. EXCEEDS CONN. INSERT DIA..
- ⚠ DIMENSIONS INDICATED WILL BE .20" LESS WHEN ORDERED WITH MOD. CODE Z.
- ⚠ FOR MULTIPLE MOD. CODES USE SEQUENCE SHOWN.
- ⚠ FOR MODIFICATION C AND ENTRY 24, ADD .188" TO LENGTH SHOWN.
- ⚠ PROVIDED ON CONNECTOR CODES 18, 21, 22 AND 51.
- ⚠ NOT PROVIDED ON CONNECTOR CODES 36, 38, 54, & 55.
- ⚠ FOR SHROUD INSTEAD OF O-RING USE CONNECTOR CODE 36.
- ⚠ FOR SHROUD INSTEAD OF O-RING USE CONNECTOR CODE 38.
- ⚠ FOR THRU TEETH AND SHROUD USE CONNECTOR CODE 55.
- ⚠ FOR CODES 36 AND 38 SELF-LOCKING HEX COUPLING IS STANDARD. "H" MOD. IS SELF-LOCKING SQUARE COUPLING.

* THIS DOCUMENT INCOMPLETE WITHOUT "ENTRY SPECIFICATION SHEET".

UNCONTROLLED COPY



**TABLE II — CONNECTOR CODE 22
 BENDIX, COMMERCIAL, PT**CE**

ORDER NO.	SHELL SIZE	A UNIFIED THD. CLASS 2B	ØC MAX.	D MAX.	E MAX. △4	F MAX.	G MAX. △4 △6	ØH ±.031	BAND MAX. 1 PIECE ENTRY	MOD. C MAX. 1 PIECE ENTRY
0 8	8	.438-28	.72	.85	1.16	1.375	1.30	.562	0 5	0 7
1 0	10	.562-24	.85	.88	1.17	1.375	1.35	.688	0 6	0 8
1 2	12	.688-24	.97	.93	1.20	1.594	1.40	.812	0 8	1 0
1 4	14	.812-20	1.10	.98	1.23	1.688	1.50	.938	1 0	1 2
1 6	16	.938-20	1.22	1.03	1.25	1.906	1.55	1.062	1 2	1 6
1 8	18	1.062-18	1.35	1.06	1.28	1.969	1.60	1.188	1 4	1 8
2 0	20	1.188-18	1.47	1.10	1.30	2.188	1.65	1.312	1 6	2 0
2 2	22	1.312-18	1.60	1.16	1.33	2.250	1.75	1.438	1 8	2 0
2 4	24	1.438-18	1.72	1.25	1.36	2.281	1.80	1.562	2 0	2 4

NOTES:

1. ASSEMBLY IDENT. PER MIL-STD-130.
2. MATERIAL: COMPONENTS — ALUM. ALLOY
O-RING — SILICONE
- △3 "2 PIECE" CONFIG. SUPPLIED WHEN CABLE ENTRY DIA. EXCEEDS CONN. INSERT DIA..
- △4 DIMENSIONS INDICATED WILL BE .20" LESS WHEN ORDERED WITH MOD. CODE Z.
- △5 FOR MULTIPLE MOD. CODES USE SEQUENCE SHOWN.
- △6 FOR MODIFICATION C AND ENTRY 24, ADD .188" TO LENGTH SHOWN.
- △11 PROVIDED ON CONNECTOR CODES 18, 21, 22 AND 51.
- △13 NOT PROVIDED ON CONNECTOR CODES 36, 38, 54, & 55.
- △14 FOR SHROUD INSTEAD OF O-RING USE CONNECTOR CODE 36.
- △15 FOR SHROUD INSTEAD OF O-RING USE CONNECTOR CODE 38.
- △16 FOR THRU TEETH AND SHROUD USE CONNECTOR CODE 55.

* THIS DOCUMENT INCOMPLETE WITHOUT "ENTRY SPECIFICATION SHEET".

UNCONTROLLED COPY



**TABLE II — CONNECTOR CODE 24
 MIL-C-26482, SERIES 1 (07)**

ORDER NO.	SHELL SIZE	<i>A</i> UNIFIED THD. CLASS 2A	<i>C</i> MAX. DIA.	<i>D</i> MAX.	<i>E</i> MAX. △4.	<i>F</i> MAX.	<i>G</i> MAX. △4.	∅ <i>H</i> ±.031	△3.
0 8	8	.625-24	.781	.79	1.15	1.47	1.38	.750	0 5
1 0	10	.750-20	.906	.81	1.17	1.72	1.44	.875	0 6
1 2	12	.875-20	1.031	.84	1.20	1.78	1.50	1.000	0 8
1 4	14	1.000-20	1.156	.86	1.23	1.91	1.56	1.125	1 0
1 6	16	1.125-18	1.281	.89	1.25	2.06	1.63	1.250	1 2
1 8	18	1.250-18	1.406	.90	1.26	2.16	1.69	1.375	1 4
2 0	20	1.375-18	1.531	.99	1.29	2.28	1.75	1.500	1 6
2 2	22	1.500-18	1.656	1.01	1.32	2.35	1.81	1.625	1 8
2 4	24	1.625-18	1.781	1.04	1.34	2.41	1.88	1.750	2 0

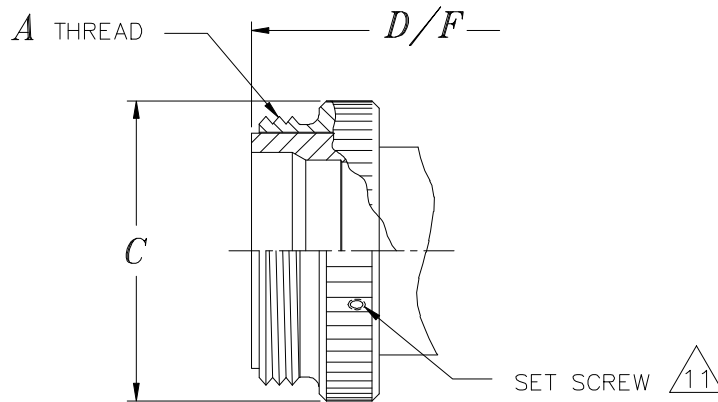

CODE 24 ONLY

NOTES:

- 1. ASSEMBLY IDENT. PER MIL-STD-130.
- 2. MATERIAL: COMPONENTS — ALUM. ALLOY
O'RING — SILICONE
- △3 "2 PIECE" CONFIG. SUPPLIED WHEN CABLE ENTRY DIA. EXCEEDS CONN. INSERT DIA..
- △4 DIMENSIONS INDICATED WILL BE .20" LESS WHEN ORDERED WITH MOD. CODE Z.
- △5 FOR MULTIPLE MOD. CODES USE SEQUENCE SHOWN.
- △6 FOR MODIFICATION C AND ENTRY 24, ADD .188" TO LENGTH SHOWN.
- △11 PROVIDED ON CONNECTOR CODES 18, 21, 22, 24 AND 51.
- △13 NOT PROVIDED ON CONNECTOR CODES 36, 38, 54, & 55.
- △14 FOR SHROUD INSTEAD OF O-RING USE CONNECTOR CODE 36.
- △15 FOR SHROUD INSTEAD OF O-RING USE CONNECTOR CODE 38.
- △16 FOR THRU TEETH AND SHROUD USE CONNECTOR CODE 55.

* THIS DOCUMENT INCOMPLETE WITHOUT "ENTRY SPECIFICATION SHEET".

UNLESS OTHERWISE SPECIFIED DIMENSIONS ARE IN INCHES	MATERIAL AND FINISH PER NOTES DO NOT SCALE DRAWING	TOLERANCES: .XX = ± .06 .XXX = ± .03 ANGLES = ± 2'	CAGE CODE 31461	SALES 217-24	DR ATP 10/11/06	CHK G.FISH 10/11/06	APP GF	REV. A
--------------------------------------------------------	-------------------------------------------------------	-------------------------------------------------------------	--------------------	-----------------	-----------------------	---------------------------	-----------	-----------

UNCONTROLLED COPY



**TABLE II — CONNECTOR CODE 40
 MIL-C-38999, SERIES III & IV**

ORDER NO.	SHELL SIZE		A METRIC THD. CLASS 6H	ØC MAX.	D MAX.	E MAX. △4	F MAX.	G MAX. △4	ØH ±.031	BAND MAX. 1 PIECE ENTRY	MOD. C MAX. 1 PIECE ENTRY
	COM'L.	MIL.									
0 8	9	A	M12 x 1.0	.703	.52	1.15	.84	1.28	.625	0 4	0 5
1 0	11	B	M15 x 1.0	.827	.54	1.17	.97	1.34	.750	0 6	0 8
1 2	13	C	M18 x 1.0	.953	.57	1.20	1.09	1.41	.875	0 8	1 0
1 4	15	D	M22 x 1.0	1.077	.59	1.23	1.22	1.47	1.000	1 0	1 2
1 6	17	E	M25 x 1.0	1.203	.62	1.25	1.34	1.53	1.125	1 2	1 6
1 8	19	F	M28 x 1.0	1.327	.63	1.26	1.41	1.59	1.250	1 3	1 6
2 0	21	G	M31 x 1.0	1.453	.66	1.29	1.53	1.66	1.375	1 5	1 8
2 2	23	H	M34 x 1.0	1.577	.68	1.32	1.66	1.72	1.500	1 7	2 0
2 4	25	J	M37 x 1.0	1.703	.71	1.34	1.78	1.78	1.625	1 9	2 0

NOTES:

1. ASSEMBLY IDENT. PER MIL-STD-130.
2. MATERIAL: COMPONENTS — ALUM. ALLOY
O-RING — SILICONE
- △3 "2 PIECE" CONFIG. SUPPLIED WHEN CABLE ENTRY DIA. EXCEEDS CONN. INSERT DIA..
- △4 DIMENSIONS INDICATED WILL BE .20" LESS WHEN ORDERED WITH MOD. CODE Z.
- △5 FOR MULTIPLE MOD. CODES USE SEQUENCE SHOWN.
- △11 PROVIDED ON CONNECTOR CODES 18 AND 21 ONLY.
- △13 NOT PROVIDED ON CONNECTOR CODES 36, 38, 54, & 55.
- △14 FOR SHROUD INSTEAD OF O-RING USE CONNECTOR CODE 36.
- △15 FOR SHROUD INSTEAD OF O-RING USE CONNECTOR CODE 38.
- △16 FOR THRU TEETH AND SHROUD USE CONNECTOR CODE 55.

* THIS DOCUMENT INCOMPLETE WITHOUT "ENTRY SPECIFICATION SHEET".

UNLESS OTHERWISE SPECIFIED DIMENSIONS ARE IN INCHES	MATERIAL AND FINISH PER NOTES DO NOT SCALE DRAWING	TOLERANCES: .XX = ± .06 .XXX = ± .03 ANGLES = ± 2°	CAGE CODE 31461	0\CAT\4\ 217-40	DR RGW 11-15-89	CHK GF 11-20-89	APP GF 11-20-89	REV. F
--------------------------------------------------------	-------------------------------------------------------	-------------------------------------------------------------	--------------------	--------------------	--------------------	--------------------	--------------------	-----------

UNCONTROLLED COPY



**TABLE II — CONNECTOR CODE 41
 MIL-C-38999, SERIES I & II**

ORDER NO.	SHELL SIZE		A UNIFIED THD. CLASS 2B	C MAX. DIA.	D MAX.	E MAX. △	F MAX.	G MAX. △	H MAX. DIA.	BAND MAX. 1 PIECE ENTRY	MOD. C MAX. 1 PIECE ENTRY
	SER. II	SER. I									
0 8	8	9	.438-28	.703	.52	1.15	.84	1.28	.813	0 4	0 5
1 0	10	11	.562-24	.827	.54	1.17	.97	1.34	.938	0 6	0 8
1 2	12	13	.688-24	.953	.57	1.20	1.09	1.41	1.125	0 8	1 0
1 4	14	15	.812-20	1.077	.59	1.23	1.22	1.47	1.250	1 0	1 2
1 6	16	17	.938-20	1.203	.62	1.25	1.34	1.53	1.375	1 2	1 6
1 8	18	19	1.062-18	1.327	.63	1.26	1.41	1.59	1.500	1 3	1 6
2 0	20	21	1.188-18	1.453	.66	1.29	1.53	1.66	1.625	1 5	1 8
2 2	22	23	1.312-18	1.577	.68	1.32	1.66	1.72	1.750	1 7	2 0
2 4	24	25	1.438-18	1.703	.71	1.34	1.78	1.78	1.875	1 9	2 0

NOTES:

1. ASSEMBLY IDENT. PER MIL-STD-130.
2. MATERIAL: COMPONENTS — ALUM. ALLOY
O’RING — SILICONE
- △3 "2 PIECE" CONFIG. SUPPLIED WHEN CABLE ENTRY DIA. EXCEEDS CONN. INSERT DIA..
- △4 DIMENSIONS INDICATED WILL BE .20" LESS WHEN ORDERED WITH MOD. CODE Z.
- △5 FOR MULTIPLE MOD. CODES USE SEQUENCE SHOWN.
- △11 PROVIDED ON CONNECTOR CODES 18 AND 21 ONLY.
- △13 NOT PROVIDED ON CONNECTOR CODES 36, 38, 54, & 55.
- △14 FOR SHROUD INSTEAD OF O-RING USE CONNECTOR CODE 36.
- △15 FOR SHROUD INSTEAD OF O-RING USE CONNECTOR CODE 38.
- △16 FOR THRU TEETH AND SHROUD USE CONNECTOR CODE 55.
- △17 FOR CODES 36 AND 38 SELF-LOCKING HEX COUPLING IS STANDARD. "H" MOD. IS SELF-LOCKING SQUARE COUPLING.

* THIS DOCUMENT INCOMPLETE WITHOUT "ENTRY SPECIFICATION SHEET".

UNLESS OTHERWISE SPECIFIED DIMENSIONS ARE IN INCHES	MATERIAL AND FINISH PER NOTES DO NOT SCALE DRAWING	TOLERANCES: .XX = ± .06 .XXX = ± .03 ANGLES = ± 2°	CAGE CODE 31461	0\CAT\4\ 217-41	DR RGW 11-15-91	CHK GF 11-20-91	APP	REV. F
--------------------------------------------------------	-------------------------------------------------------	----------------------------------------------------------	--------------------	--------------------	--------------------	--------------------	-----	-----------

UNCONTROLLED COPY



TABLE II — CONNECTOR CODE 51
 MIL-C-26500, ALUMINUM

ORDER NO.	SHELL SIZE	<i>A</i> UNIFIED THD. CLASS 2B	ϕC MAX.	<i>D</i> MAX.	<i>E</i> MAX. $\triangle 4$	<i>F</i> MAX.	ϕH $\pm .031$	<i>G</i> MAX. $\triangle 4$	BAND MAX. 1 PIECE ENTRY	MOD. C MAX. 1 PIECE ENTRY
0 8	8	.438-28	.703	.62	1.15	1.00	.562	1.28	0 4	0 5
1 0	10	.562-24	.827	.64	1.17	1.06	.688	1.34	0 6	0 8
1 2	12	.750-20	1.010	.67	1.20	1.19	.875	1.41	0 8	1 0
1 4	14	.812-20	1.077	.72	1.23	1.31	.938	1.47	1 0	1 2
1 6	16	.938-20	1.203	.72	1.25	1.44	1.062	1.53	1 2	1 6
1 8	18	1.062-18	1.327	.76	1.26	1.56	1.188	1.59	1 3	1 6
2 0	20	1.188-18	1.453	.78	1.29	1.69	1.312	1.66	1 5	1 8
2 2	22	1.312-18	1.577	.79	1.32	1.81	1.438	1.72	1 7	2 0
2 4	24	1.438-18	1.703	.82	1.34	1.94	1.562	1.78	1 9	2 0

NOTES:

1. ASSEMBLY IDENT. PER MIL-STD-130.
2. MATERIAL: COMPONENTS — ALUM. ALLOY
O’RING — SILICONE
- $\triangle 3$ "2 PIECE" CONFIG. SUPPLIED WHEN CABLE ENTRY DIA. EXCEEDS CONN. INSERT DIA..
- $\triangle 4$ DIMENSIONS INDICATED WILL BE .20" LESS WHEN ORDERED WITH MOD. CODE Z.
- $\triangle 5$ FOR MULTIPLE MOD. CODES USE SEQUENCE SHOWN.
- $\triangle 11$ PROVIDED ON CONNECTOR CODES 18, 21 & 51 ONLY
- $\triangle 13$ NOT PROVIDED ON CONNECTOR CODES 36, 38, 54, & 55.
- $\triangle 14$ FOR SHROUD INSTEAD OF O-RING USE CONNECTOR CODE 36.
- $\triangle 15$ FOR SHROUD INSTEAD OF O-RING USE CONNECTOR CODE 38.
- $\triangle 16$ FOR THRU TEETH AND SHROUD USE CONNECTOR CODE 55.

* THIS DOCUMENT INCOMPLETE WITHOUT "ENTRY SPECIFICATION SHEET".

UNLESS OTHERWISE SPECIFIED DIMENSIONS ARE IN INCHES	MATERIAL AND FINISH PER NOTES DO NOT SCALE DRAWING	TOLERANCES: .XX = $\pm .06$.XXX = $\pm .03$ ANGLES = $\pm 2'$	CAGE CODE 31461	SALES 217-51	DR 9-25-97	KP	CHK GF	APP 9-25-97	REV. A
--------------------------------------------------------	-------------------------------------------------------	-------------------------------------------------------------------------	--------------------	-----------------	---------------	----	-----------	----------------	-----------

UNCONTROLLED COPY



TABLE II - CONNECTOR CODE 54

MIL-C-26482, SERIES 2
MIL-C-5015G, 3400 SERIES
MIL-C-81703, SERIES 3
MIL-C-83723, SERIES I & III
NAS1599

ORDER NO.	SHELL SIZE		A UNIFIED THD. CLASS 2B	C MAX. DIA.	D MAX.	E MAX. 4/6	F MAX.	G MAX. 4/6	H MAX. DIA.	BAND MAX. 1 PIECE ENTRY	MOD. C MAX. 1 PIECE ENTRY
	8	7									
0 3	3	-	.562-24	.669	.55	1.15	.84	1.28	.880	0 4	0 5
0 8	-	8,8S	.500-20	.617	.55	1.15	.84	1.28	.880	0 4	0 5
1 0	-	10,10S,10SL	.625-24	.734	.57	1.17	.97	1.31	.942	0 6	0 7
1 2	7	12,12S	.750-20	.858	.60	1.20	1.09	1.38	1.068	0 8	1 0
1 4	12	14,14S	.875-20	.984	.61	1.21	1.16	1.44	1.192	0 8	1 0
1 6	19	16,16S	1.000-20	1.112	.64	1.24	1.28	1.50	1.318	1 0	1 2
1 8	27	18	1.062-18	1.218	.65	1.25	1.34	1.53	1.380	1 2	1 6
2 0	37	20	1.188-18	1.345	.68	1.28	1.47	1.59	1.505	1 4	1 8
2 2	-	22	1.312-18	1.468	.70	1.30	1.59	1.66	1.630	1 6	2 0
2 4	-	24	1.438-18	1.593	.73	1.33	1.72	1.72	1.755	1 8	2 0
2 8	-	28	1.750-18	1.969	.78	1.38	1.97	1.88	2.068	2 0	2 4
3 2	-	32	2.000-18	2.219	.83	1.43	2.22	2.00	2.318	2 4	2 4
3 6	-	36	2.250-16	2.469	.86	1.46	2.34	2.13	2.568	2 4	2 4
4 0	-	40	2.500-16	2.719	.91	1.51	2.59	2.25	2.818	2 4	2 4
4 4	-	44	2.750-16	2.969	.96	1.56	2.84	2.38	3.068	2 4	2 4
4 8	-	48	3.000-16	3.219	1.01	1.61	3.09	2.50	3.318	2 4	2 4
6 1	61	-	1.500-18	1.653	.74	1.34	1.78	1.75	1.818	1 8	2 0

NOTES:

- 1. ASSEMBLY IDENT. PER MIL-STD-130.
- 2. MATERIAL: COMPONENTS - ALUM. ALLOY
O-RING - SILICONE

- 3 "2 PIECE" CONFIG. SUPPLIED WHEN CABLE ENTRY DIA. EXCEEDS CONN. INSERT DIA..
- 4 DIMENSIONS INDICATED WILL BE .20" LESS WHEN ORDERED WITH MOD. CODE Z.
- 5 FOR MULTIPLE MOD. CODES USE SEQUENCE SHOWN.
- 6 FOR MODIFICATION C AND ENTRY 24, ADD .188" TO LENGTH SHOWN.
- 7 SIZES PER MIL-C-5015 (3400 SERIES), MIL-C-26482 (SERIES 2), MIL-C-83723 (SERIES I & III), & NAS1599.

- 8 SIZES PER MIL-C-81703, SERIES 3.
- 11 PROVIDED ON CONNECTOR CODES 18 AND 21 ONLY.
- 13 NOT PROVIDED ON CONNECTOR CODES 36, 38, 54, & 55.
- 14 FOR SHROUD INSTEAD OF O-RING USE CONNECTOR CODE 36.
- 15 FOR SHROUD INSTEAD OF O-RING USE CONNECTOR CODE 38.
- 16 FOR THRU TEETH AND SHROUD USE CONNECTOR CODE 55.
- 17 FOR CODES 36 AND 38 SELF-LOCKING HEX COUPLING IS STANDARD. "H" MOD. IS SELF-LOCKING SQUARE COUPLING.

*THIS DOCUMENT INCOMPLETE WITHOUT "ENTRY SPECIFICATION SHEET".

UNLESS OTHERWISE SPECIFIED DIMENSIONS ARE IN INCHES	MATERIAL AND FINISH PER NOTES DO NOT SCALE DRAWING	TOLERANCES: .XX = ± .06 .XXX = ± .03 ANGLES = ± 2°	CAGE CODE 31461	O\CAT\4\ 217-54	DR TW 12-05-89	CHK GF 12-07-89	APP	REV. F
--------------------------------------------------------	-------------------------------------------------------	----------------------------------------------------------	--------------------	--------------------	-------------------	--------------------	-----	-----------

UNCONTROLLED COPY

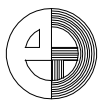

TABLE II — CONNECTOR CODE 61
 MIL-C-81511, SERIES 1, 2, 3, & 4

ORDER NO.	SHELL SIZE		A UNIFIED THD. CLASS 2B	ØC MAX.	D MAX.	E MAX. ⚠4	F MAX.	G MAX. ⚠4 ⚠6	ØH ±.031	BAND MAX. 1 PIECE ENTRY	MOD. C MAX. 1 PIECE ENTRY
	COM'L.	MIL.									
0 8	8	A	.500-28	.765	.76	1.17	1.25	1.28	.625	0 6	0 8
1 0	10	B	.625-28	.890	.79	1.20	1.38	1.34	.750	0 8	1 0
1 4	14	D	.875-28	1.140	.84	1.25	1.63	1.47	1.000	1 2	1 6
1 6	16	E	1.000-28	1.265	.86	1.28	1.75	1.53	1.125	1 4	1 8
1 8	18	F	1.125-28	1.390	.89	1.30	1.88	1.59	1.250	1 6	2 0
2 0	20	G	1.250-28	1.515	.92	1.33	2.00	1.66	1.375	1 8	2 0
2 2	22	H	1.375-28	1.640	.94	1.35	2.13	1.72	1.500	2 0	2 4
2 4	24	J	1.500-28	1.765	.97	1.38	2.25	1.78	1.625	2 2	2 4

NOTES:

1. ASSEMBLY IDENT. PER MIL-STD-130.
2. MATERIAL: COMPONENTS — ALUM. ALLOY
O-RING — SILICONE
- ⚠3 "2 PIECE" CONFIG. SUPPLIED WHEN CABLE ENTRY DIA. EXCEEDS CONN. INSERT DIA..
- ⚠4 DIMENSIONS INDICATED WILL BE .20" LESS WHEN ORDERED WITH MOD. CODE Z.
- ⚠5 FOR MULTIPLE MOD. CODES USE SEQUENCE SHOWN.
- ⚠6 FOR MODIFICATION C AND ENTRY 24, ADD .188" TO LENGTH SHOWN.
- ⚠11 PROVIDED ON CONNECTOR CODES 18 AND 21 ONLY.
- ⚠13 NOT PROVIDED ON CONNECTOR CODES 36, 38, 54, & 55.
- ⚠14 FOR SHROUD INSTEAD OF O-RING USE CONNECTOR CODE 36.
- ⚠15 FOR SHROUD INSTEAD OF O-RING USE CONNECTOR CODE 38.
- ⚠16 FOR THRU TEETH AND SHROUD USE CONNECTOR CODE 55.

* THIS DOCUMENT INCOMPLETE WITHOUT "ENTRY SPECIFICATION SHEET".

UNLESS OTHERWISE SPECIFIED DIMENSIONS ARE IN INCHES	MATERIAL AND FINISH PER NOTES DO NOT SCALE DRAWING	TOLERANCES: .XX = ± .06 .XXX = ± .03 ANGLES = ± 2'	CAGE CODE 31461	SALES 217-61	DR TW 02-07-90	CHK GF 02-08-90	APP GIG 10-26-92	REV. C
--------------------------------------------------------	-------------------------------------------------------	-------------------------------------------------------------	--------------------	-----------------	-------------------	--------------------	---------------------	-----------

UNCONTROLLED COPY

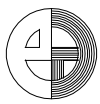

TABLE II — CONNECTOR CODE 64
 LITTON VEAM CIR SERIES

ORDER NO.	SHELL SIZE	A UNIFIED THD. CLASS 2B	ØC MAX.	D MAX.	E MAX. △4	F MAX.	G MAX. △4△6	BAND MAX. 1 PIECE ENTRY	MOD. C MAX. 1 PIECE ENTRY
1 2	12	.625-24	.890	.82	1.17	1.19	1.31	0 6	0 8
1 4	14	.750-20	.953	.83	1.18	1.25	1.38	0 7	0 9
1 6	16	.875-20	1.140	.85	1.20	1.31	1.44	0 8	1 0
1 8	18	1.000-20	1.265	.90	1.25	1.56	1.50	1 2	1 6
2 0	20	1.125-18	1.390	.90	1.25	1.56	1.56	1 2	1 6
2 2	22	1.250-18	1.515	.91	1.26	1.63	1.63	1 3	1 6
2 4	24	1.375-18	1.640	.96	1.32	1.87	1.69	1 7	2 0
2 8	28	1.625-18	1.890	.99	1.34	2.00	1.81	1 9	2 0
3 2	32	1.875-16	2.140	1.04	1.39	2.25	1.94	2 3	2 4
3 6	36	2.062-16	2.327	1.11	1.46	2.56	2.06	2 4	2 4
4 0	40	2.312-16	2.577	1.16	1.51	2.81	2.19	2 4	2 4

NOTES:

1. ASSEMBLY IDENT. PER MIL-STD-130.
2. MATERIAL: COMPONENTS — ALUM. ALLOY
O-RING — SILICONE
- △3 "2 PIECE" CONFIG. SUPPLIED WHEN CABLE ENTRY DIA. EXCEEDS CONN. INSERT DIA..
- △4 DIMENSIONS INDICATED WILL BE .20" LESS WHEN ORDERED WITH MOD. CODE Z.
- △5 FOR MULTIPLE MOD. CODES USE SEQUENCE SHOWN.
- △6 FOR MODIFICATION C AND ENTRY 24, ADD .188" TO LENGTH SHOWN.
- △11 PROVIDED ON CONNECTOR CODES 18 AND 21 ONLY.
- △13 NOT PROVIDED ON CONNECTOR CODES 36, 38, 54, & 55.
- △14 FOR SHROUD INSTEAD OF O-RING USE CONNECTOR CODE 36.
- △15 FOR SHROUD INSTEAD OF O-RING USE CONNECTOR CODE 38.
- △16 FOR THRU TEETH AND SHROUD USE CONNECTOR CODE 55.

* THIS DOCUMENT INCOMPLETE WITHOUT "ENTRY SPECIFICATION SHEET".

UNCONTROLLED COPY

TABLE I ~ CONNECTOR INTERFACE DATA

ORDER NUMBER	SHELL SIZE		A R. H. THREAD CLASS 2A	B MAX. O.D.	C ±.09
	STK, RTK	DM, DS ETC.			
08	8		.375 - 32 UNEF	.729	.66
03	10	3	.500 - 28 UNEF	.864	.69
07		7	.625 - 24 UNEF	.989	.71
12	14	12	.750 - 20 UNEF	1.114	.74
19	16	19	.875 - 20 UNEF	1.208	.75
27	18	27	1.000 - 20 UNEF	1.458	.80
37		37	1.188 - 18 UNEF	1.582	.83
61		61	1.500 - 18 UNEF	1.958	.88

TABLE II ~ CABLE ENTRY DATA

ENTRY SIZE	W DIA.	X DIA.	Y DIA.	Z ±.020
04	.500	.334	.375	.250
05	.562	.396	.438	.312
06	.625	.459	.500	.375
07	.688	.521	.562	.438
08	.750	.584	.625	.500
09	.812	.646	.688	.562
10	.875	.709	.750	.625
11	.938	.771	.812	.688
12	1.000	.834	.875	.750
13	1.062	.896	.938	.812
14	1.125	.959	1.000	.875

UNCONTROLLED COPY

D ±.094 △ 5	E ±.094	F ±.094 △ 5	AVAILABLE ENTRY SIZES
1.116	.875	1.281	04
1.142	1.062	1.344	04 THRU 06
1.168	1.125	1.406	04 THRU 08
1.194	1.250	1.469	04 THRU 10
1.207	1.312	1.500	04 THRU 12
1.259	1.562	1.625	04 THRU 14
1.285	1.688	1.688	04 THRU 16
.350	1.938	1.844	04 THRU 20

A THREAD
(TYP.)

UNCONTROLLED COPY

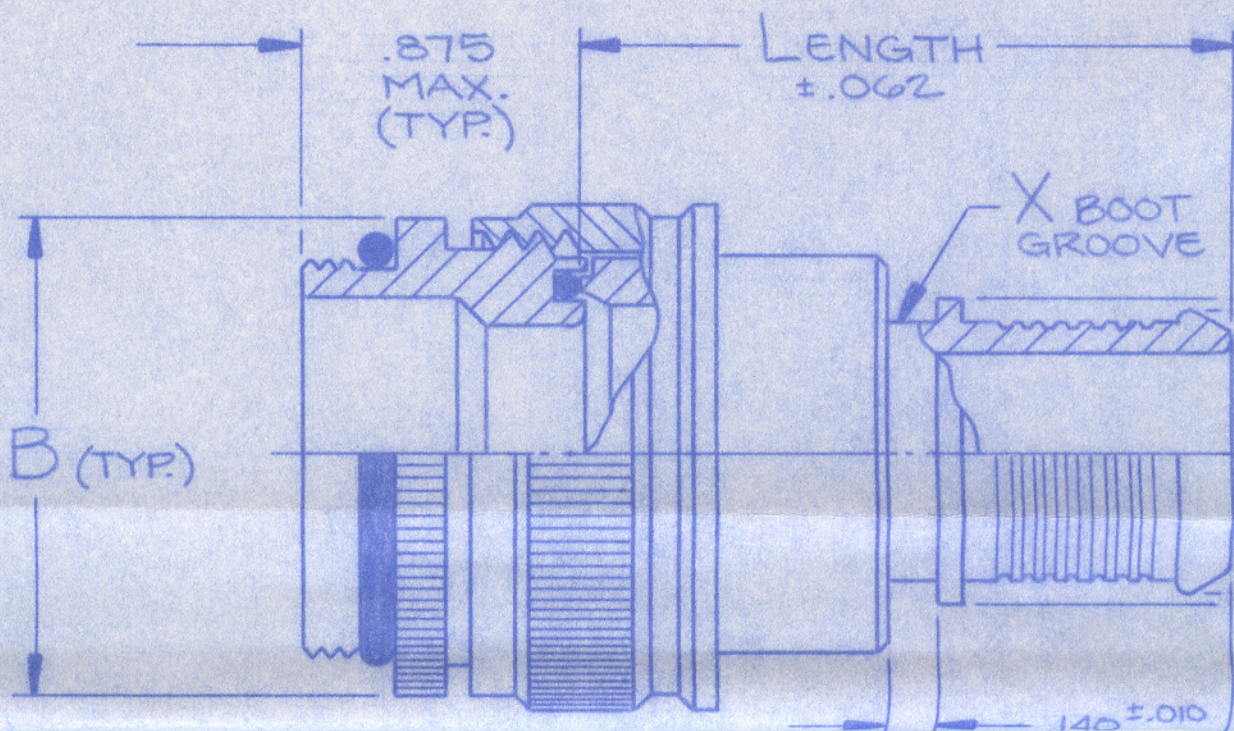

UNCONTROLLED COPY

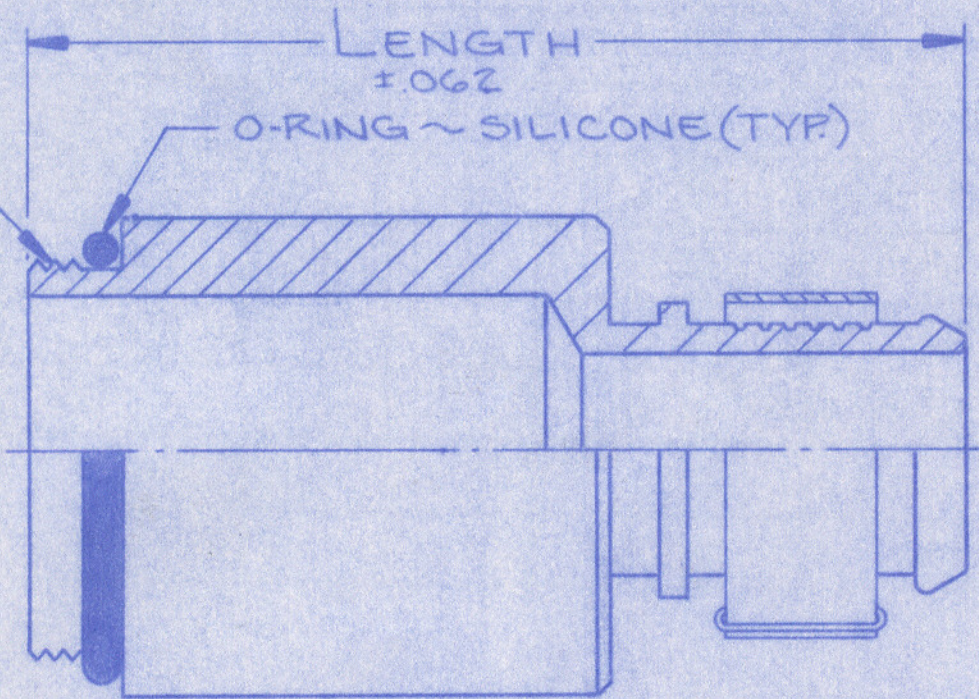

STYLE B

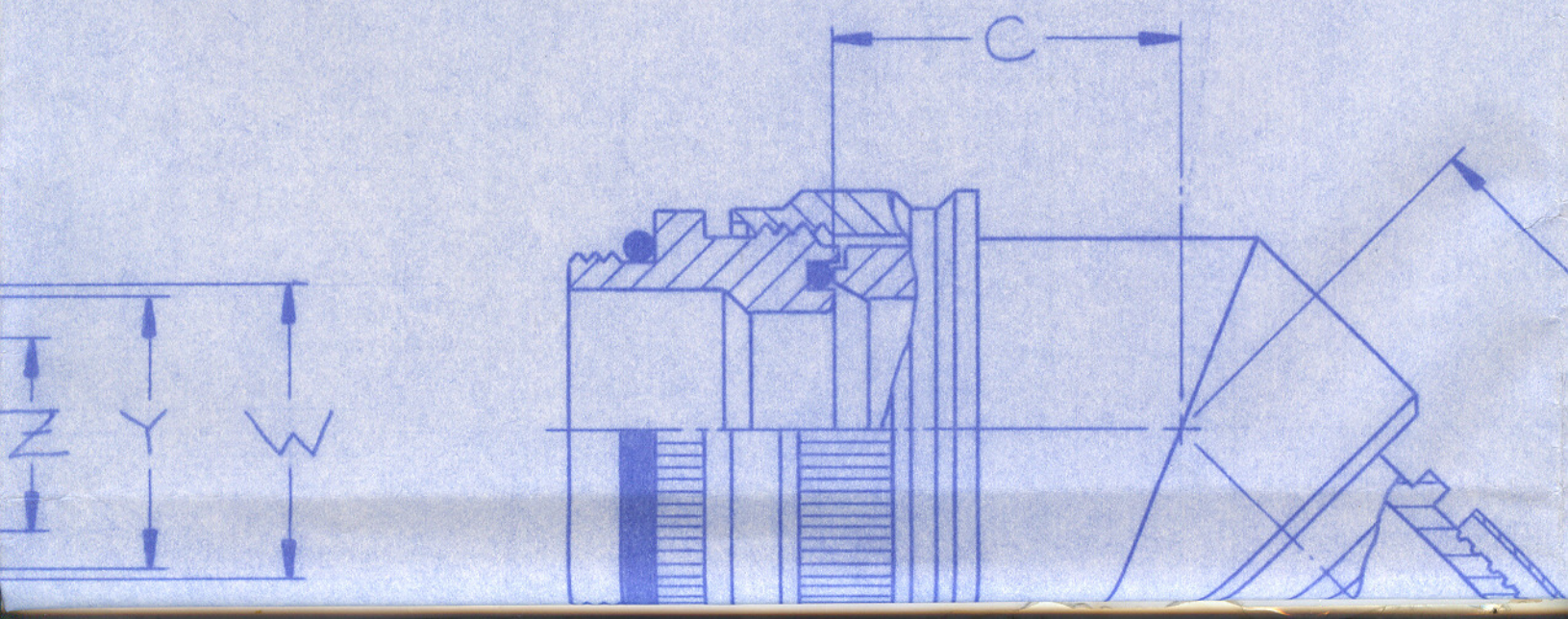

L/A	DESCRIPTION	DATE	APPROVED
A	REVISED PER ECO # 17384	TDW 1-12-90	G-90

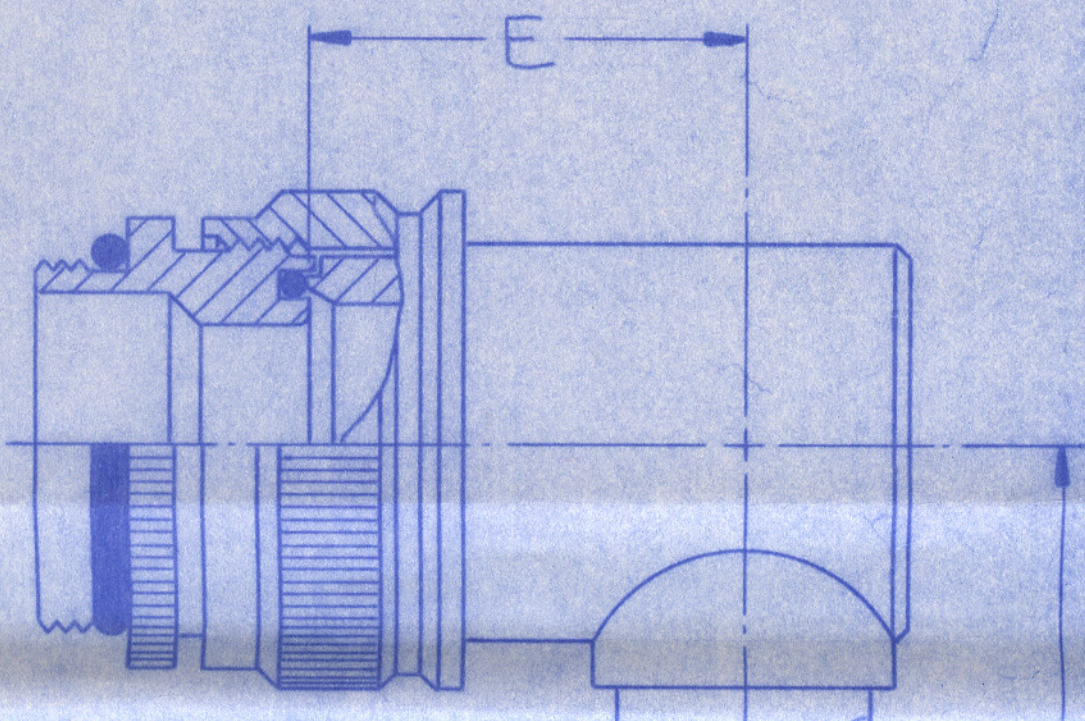

UNCONTROLLED COPY

B (TYP.)

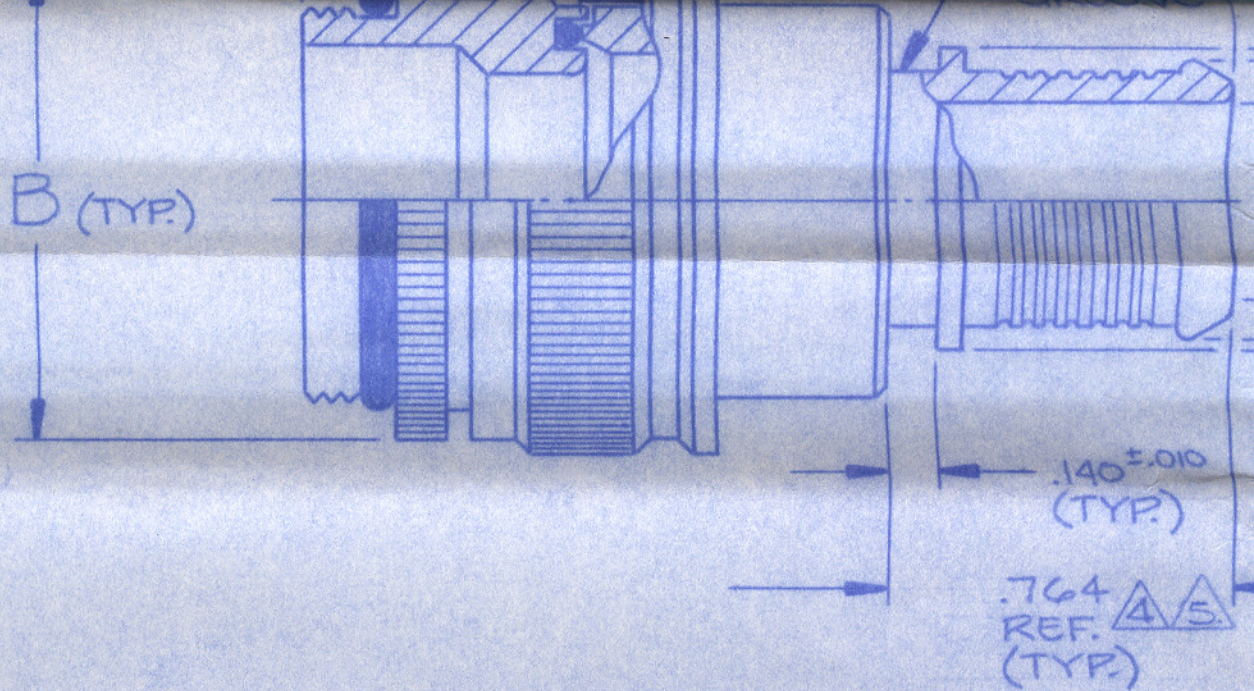

STYLE S

EMI BAND NOT SHOWN

UNCONTROLLED COPY

PART NUMBER
S 271210855 Δ

PLATING CODE NUMBER
03 ~ CADMIUM, OLIVE DRAB, PER QQ-
51 ~ ELECTROLESS NICKEL PER MIL-C-
55 ~ CADMIUM, OLIVE DRAB, PER QQ-P-
ELECTROLESS NICKEL PER MIL-C-2

LENGTH CODE NUMBER
LENGTH OF PART IS CHOSEN IN 1/4 INCH
(EXAMPLE: LENGTH CODE 06 = 1.500) (00 =
MINIMUM LENGTH WITH BOOT GROOVE (STAND
MINIMUM LENGTH WITHOUT BOOT GROOVE (MO

TERMINATION OPTIONS Δ

- 1 ~ ADAPTER ONLY
- 2 ~ ADAPTER w/ 3/8" EMI BAND
- 3 ~ ADAPTER w/ 3/8" EMI BAND AND SHRI
- 4 ~ ADAPTER w/ 1/4" EMI BAND
- 5 ~ ADAPTER w/ 1/4" EMI BAND AND SHRI

I

II

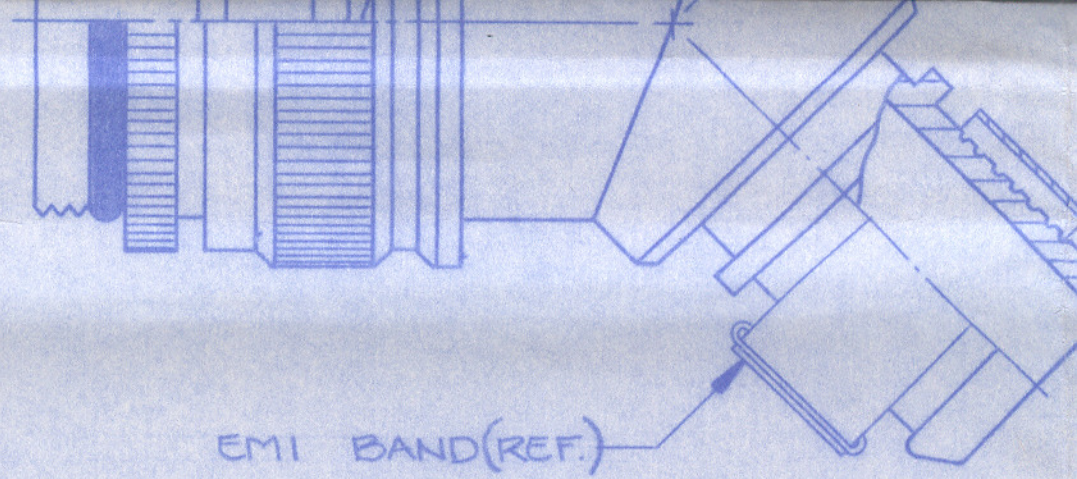
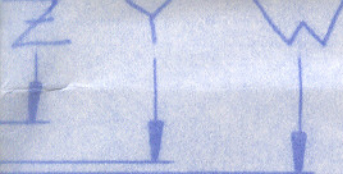

EMI BAND (REF.)

STYLE A

- ⑥ INSERT A FOR DEUT
INSERT B FOR DEUT
INSERT C FOR DEU
OMIT FOR DEUTSCH
- ⑤ DIMENSIONS INDICATE
WITH MOD CODE Z
- ④ ADD Z FOR LESS
- ③ CONSULT FACTORY

2. MATERIAL: ADAPTE
RETAINI
SHRINK

1. ASSEMBLY IDENT

NOTES:

IG, TYPE II, CLASS 3
074, CLASS 3 OR 4, GRADE B
TYPE II, CLASS 3 OVER
4, CLASS 3 OR 4, GRADE B

INCREMENTS
R STYLES A & R)
RD) = 1.500 (LENGTH CODE 06)
Z Δ) = 1.250 (LENGTH CODE 05)

K SLEEVE
K SLEEVE

ITEM NO.	NOMENCLATURE
<p>The information disclosed herein is the property of, and a proprietary item originated by ELECTRO ADAPTER, INC., who reserves all patent, proprietary design, use, sale, manufacturing and reproduction rights thereto; except for uses expressly granted to the United States Government and items which are vendor parts, disclosure shall not be made without written consent from ELECTRO ADAPTER, INC.</p>	
<p>UNLESS OTHERWISE SPECIFIED DIMENSIONS ARE IN INCHES</p>	
<p>TOLERANCES</p>	
<p>DECIMALS XX ± .06 XXX ± .031</p>	<p>ANGLES ± 2°</p>
<p>DO NOT SCALE DRAWING</p>	

UNCONTROLLED COPY



TABLE II — CONNECTOR CODE 76
 PATT 105, 603 & 608

ORDER NO.	SHELL SIZE	<i>A</i> UNIFIED THD. CLASS 2B	<i>C</i> MAX. DIA.	<i>D</i> MAX.	<i>E</i> MAX. △4	<i>F</i> MAX.	<i>G</i> MAX. △4 △6	BAND MAX. 1 PIECE ENTRY	MOD. C MAX. 1 PIECE ENTRY
0 8	8	.438-28	.703	.62	1.16	1.00	1.28	0 4	0 5
1 0	10	.562-24	.827	.63	1.17	1.06	1.34	0 7	1 0
1 2	12	.688-24	.953	.66	1.20	1.19	1.41	0 8	0 9
1 4	14	.812-20	1.077	.69	1.23	1.31	1.47	1 0	1 0
1 6	16	.938-20	1.203	.71	1.25	1.44	1.53	1 2	1 2
1 8	18	1.062-18	1.327	.74	1.28	1.56	1.59	1 4	1 6
2 0	20	1.188-18	1.453	.76	1.30	1.69	1.66	1 6	1 8
2 2	22	1.312-18	1.577	.79	1.33	1.81	1.72	1 8	2 0
2 4	24	1.438-18	1.703	.82	1.36	1.94	1.78	2 0	2 0

NOTES:

1. ASSEMBLY IDENT. PER MIL-STD-1285.
2. MATERIAL: COMPONENTS — ALUM. ALLOY
O'RING — SILICONE
- △3 "2 PIECE" CONFIG. SUPPLIED WHEN CABLE ENTRY DIA. EXCEEDS CONN. INSERT DIA..
- △4 DIMENSIONS INDICATED WILL BE .20" LESS WHEN ORDERED WITH MOD. CODE Z.
- △5 FOR MULTIPLE MOD. CODES USE SEQUENCE SHOWN.
- △6 FOR MODIFICATION C AND ENTRY 24, ADD .188" TO LENGTH SHOWN.

* THIS DOCUMENT INCOMPLETE WITHOUT "ENTRY SPECIFICATION SHEET".

UNCONTROLLED COPY

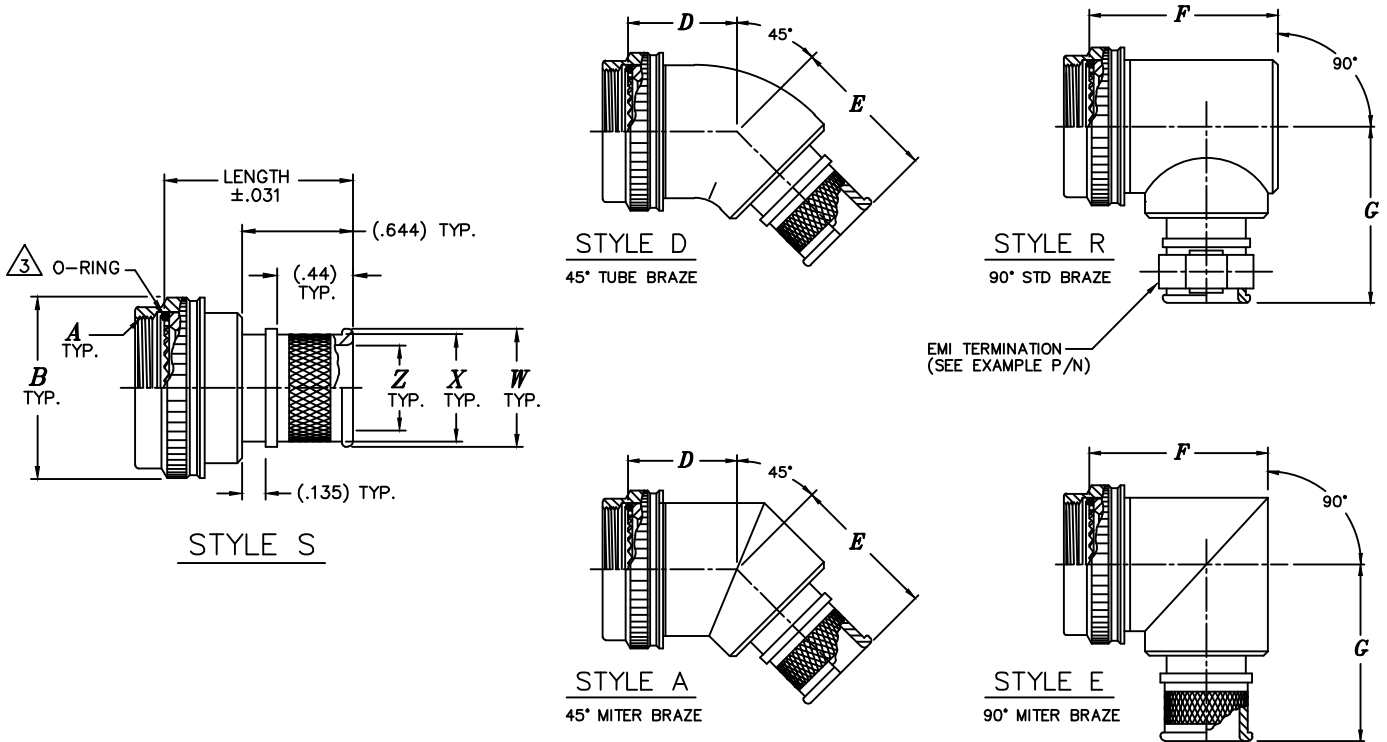

Example Part Number

271 41 S 16 10 10 8 5 5 S

BASIC ADAPTER NUMBER

STYLE
 S = STRAIGHT
 A = 45°
 R = 90°

ORDER NO. PER TABLE II

ADD 'S' FOR SELF-LOCKING COUPLING

TABLE I - CONNECTOR CODE

MILITARY SPECIFICATION	SERIES	CODE NO.
MIL-DTL-5015	3100	18
MIL-DTL-26482	1	21
MIL-DTL-26482	I (07)	24
MIL-DTL-28840	-	30
MIL-DTL-38999	III & IV	40
MIL-DTL-38999	I & II	41
MIL-DTL-26482	2	54
MIL-DTL-5015	3400	54
MIL-C-81703	3	54
MIL-DTL-83723	I	54
MIL-DTL-83723	III	54
NAS1599	-	54
LITTON VEAM CIR	-	64
AB 05	DEF. STD. 59-35 PART 1, SEC. 3	76
PATT 121	DEF. STD. 59-35 PART 1, SEC. 8	78

TABLE III - CABLE/HARNESS ENTRY DATA

ENTRY ORDER NO.	EMP BAND			BOOT P/N REF
	Z +.010 -.020 DIA.	X ±.015 DIA.	W ±.010 DIA.	
0 2	.125	.250	.312	N/A
0 3	.188	.312	.375	152-42-G-W24
0 4	.250	.375	.438	152-42-G-W24
0 5	.312	.438	.500	152-42-G-W24
0 6	.375	.500	.562	152-42-G-W24
0 7	.438	.562	.625	154-42-G-W24
0 8	.500	.625	.688	154-42-G-W24
0 9	.562	.688	.750	154-42-G-W24
1 0	.625	.750	.812	154-42-G-W24
1 2	.750	.875	.938	155-42-G-W24
1 3	.812	.937	1.000	156-42-G-W24
1 4	.875	1.000	1.062	156-42-G-W24
1 6	1.000	1.125	1.188	156-42-G-W24
1 7	1.062	1.188	1.250	157-43-G-W24
1 8	1.125	1.250	1.312	157-43-G-W24
1 9	1.188	1.313	1.375	157-43-G-W24
2 0	1.250	1.375	1.438	157-43-G-W24
2 2	1.375	1.500	1.562	158-43-G-W24
2 3	1.438	1.562	1.625	158-43-G-W24
2 4	1.500	1.625	1.688	158-43-G-W24

PLATING CODE NUMBER
 13 = ZINC COLBALT, OLIVE DRAB, PER ASTM B840-99
 55 = CADMIUM, OLIVE DRAB, PER SAE AMS-QQ-P-416, TYPE II, CLASS 3, OVER ELECTROLESS NICKEL PER AMS-C-26074, CLASS 3 OR 4, GRADE B
 10 = PASSIVATE, PER SAE AMS-QQ-P-35 (MATERIAL=SST)
 FOR ADDITIONAL FINISH OPTIONS, SEE CATALOG TABLE 4.

LENGTH CODE NUMBER
 SELECT LENGTH IN 1/4" INCREMENTS (ie: 08=2.00", 09=2.25", etc.)
 00 FOR 45° & 90° ADAPTERS (STYLES A & R)

MIN. AVAIL. LENGTH	CONNECTOR CODES (TABLE I)
1.000	40, 41, 54,
1.250	18, 21, 24, 76, 78
1.500	30, 64

TERMINATION NUMBER

- 1 = ADAPTER ONLY
- 4 = ADAPTER w/ 1/4" EMP BAND (REF. 214L0002)
- 5 = ADAPTER w/ 1/4" EMP BAND AND SHRINK BOOT (REF 214L0002)
- 6 = ADAPTER w/ 1/8" EMP BAND AND SHRINK BOOT (REF 214L0005)
- 7 = ADAPTER w/ 1/4" EMP BAND AND (REF 214L0006)
- 8 = ADAPTER w/ 1/8" EMP BAND (REF. 214L0005)
- 9 = ADAPTER w/ 1/4" EMP BAND AND SHRINK BOOT (REF 214L0006)

CONSULT FACTORY FOR TERMINATION NUMBER NOT SHOWN



CONSULT FACTORY
 FOR STYLE
 A

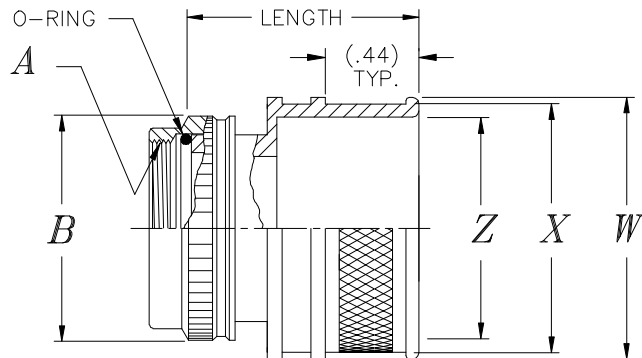

STYLE S

TABLE III - OVERSIZE ENTRY DATA		
ENTRY ORDER NO.	<i>K</i> MAX.	<i>L</i> MAX.
0 5	1.500	1.375
0 6	1.500	1.375
0 7	1.625	1.438
0 8	1.625	1.438
0 9	1.750	1.500
1 0	1.750	1.500
1 2	1.875	1.562
1 3	2.000	1.625
1 4	2.000	1.625
1 6	2.125	1.688
1 7	2.250	1.750
1 8	2.250	1.750
1 9	2.375	1.812
2 0	2.375	1.812
2 2	CONSULT FACTORY	
2 3	FOR THESE	
2 4	ENTRY SIZES	

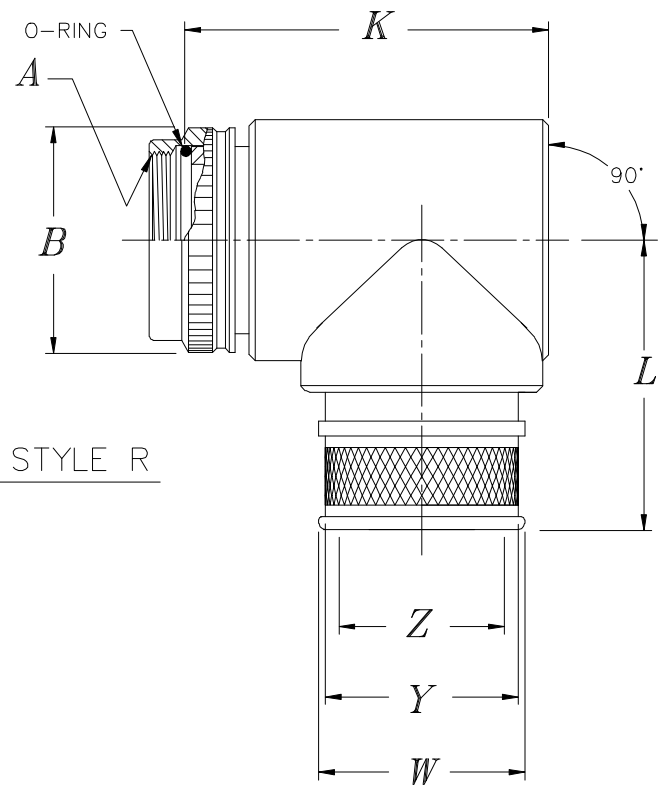

STYLE R

*THIS DOCUMENT INCOMPLETE WITHOUT
 "INTERFACE SPECIFICATION SHEET & SHEET 2"

UNCONTROLLED COPY

UNLESS OTHERWISE SPECIFIED DIMENSIONS ARE IN INCHES	MATERIAL AND FINISH PER NOTES DO NOT SCALE DRAWING	TOLERANCES: .XX = ± .06 .XXX = ± .03 ANGLES = ± 2'	CAGE CODE 31461	SALES 27121-P3	DR ATP 2/18/04	CHK	APP	REV.
--------------------------------------------------------	-------------------------------------------------------	-------------------------------------------------------------	--------------------	-------------------	----------------------	-----	-----	------



CONSULT FACTORY
 FOR STYLE
 A

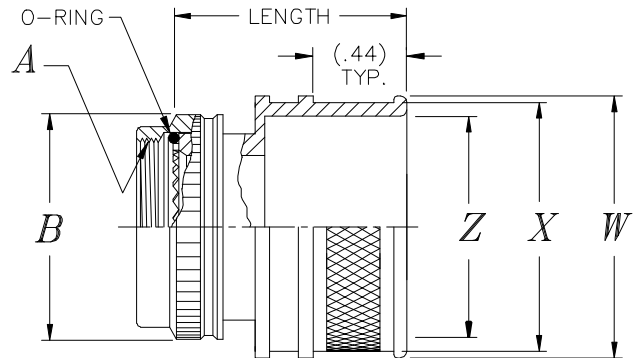

STYLE S

TABLE III - OVERSIZE ENTRY DATA		
ENTRY ORDER NO.	<i>K</i> MAX.	<i>L</i> MAX.
0 5	1.375	1.375
0 6	1.375	1.375
0 7	1.500	1.438
0 8	1.500	1.438
0 9	1.625	1.500
1 0	1.625	1.500
1 2	1.750	1.562
1 3	1.875	1.625
1 4	1.875	1.625
1 6	2.000	1.688
1 7	2.125	1.750
1 8	2.125	1.750
1 9	2.250	1.812
2 0	2.250	1.812
2 2	CONSULT FACTORY	
2 3	FOR THESE	
2 4	ENTRY SIZES	

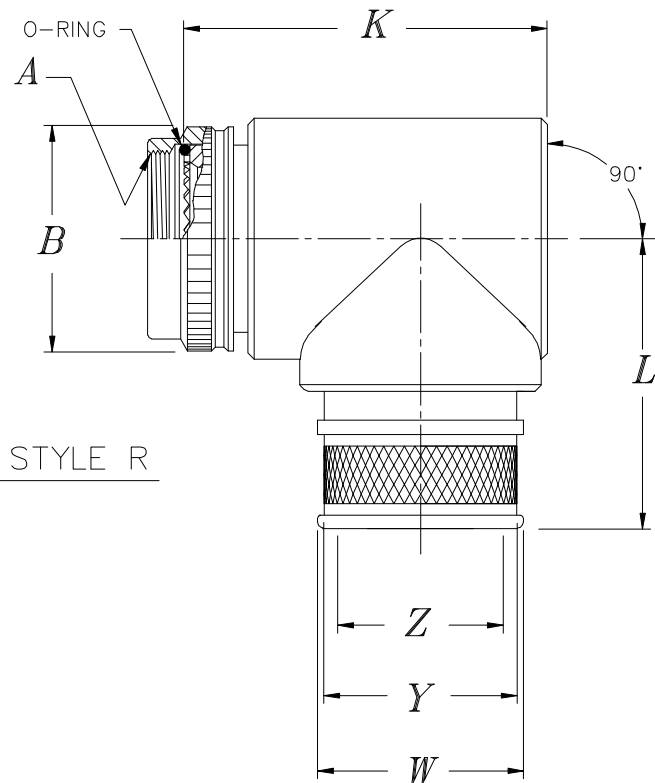

STYLE R

* THIS DOCUMENT INCOMPLETE WITHOUT
 "INTERFACE SPECIFICATION SHEET & SHEET 2"

UNCONTROLLED COPY



CONSULT FACTORY
 FOR STYLE
 A

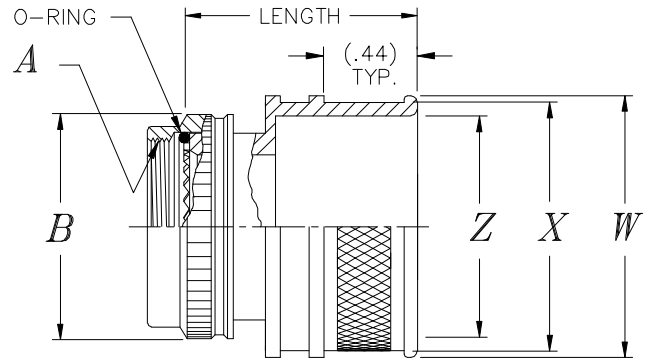

STYLE S

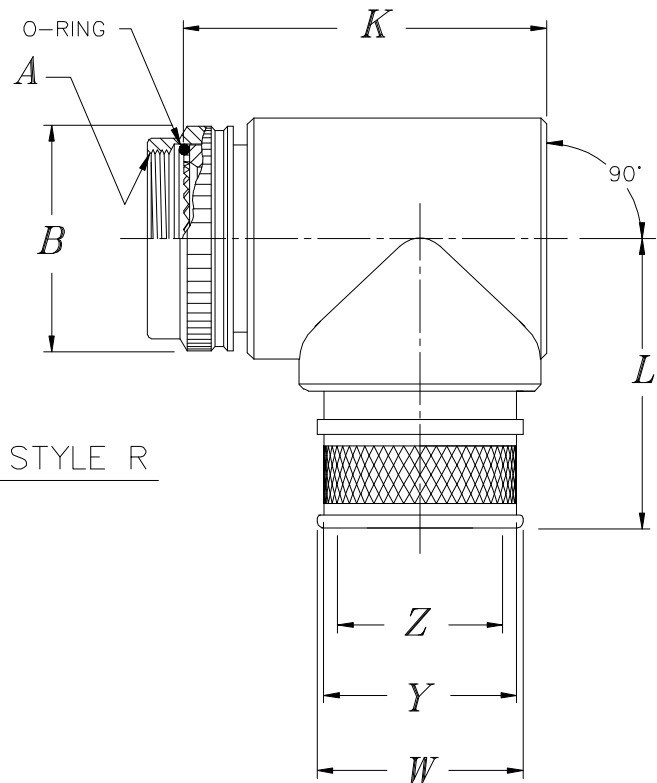

STYLE R

TABLE III - OVERSIZE ENTRY DATA		
ENTRY ORDER NO.	K MAX.	L MAX.
0 5	1.375	1.375
0 6	1.375	1.375
0 7	1.500	1.438
0 8	1.500	1.438
0 9	1.625	1.500
1 0	1.625	1.500
1 2	1.750	1.562
1 3	1.875	1.625
1 4	1.875	1.625
1 6	2.000	1.688
1 7	2.125	1.750
1 8	2.125	1.750
1 9	2.250	1.812
2 0	2.250	1.812
2 2	CONSULT FACTORY	
2 3	FOR THESE	
2 4	ENTRY SIZES	

* THIS DOCUMENT INCOMPLETE WITHOUT
 "INTERFACE SPECIFICATION SHEET & SHEET 2"

UNCONTROLLED COPY



CONSULT FACTORY
 FOR STYLE
 A

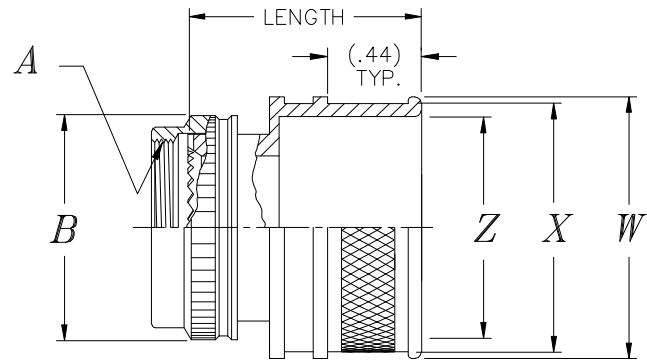

STYLE S

TABLE III - OVERSIZE ENTRY DATA		
ENTRY ORDER NO.	<i>K</i> MAX.	<i>L</i> MAX.
0 5	1.375	1.375
0 6	1.375	1.375
0 7	1.500	1.438
0 8	1.500	1.438
0 9	1.625	1.500
1 0	1.625	1.500
1 2	1.750	1.562
1 3	1.875	1.625
1 4	1.875	1.625
1 6	2.000	1.688
1 7	2.125	1.750
1 8	2.125	1.750
1 9	2.250	1.812
2 0	2.250	1.812
2 2	CONSULT FACTORY	
2 3	FOR THESE	
2 4	ENTRY SIZES	

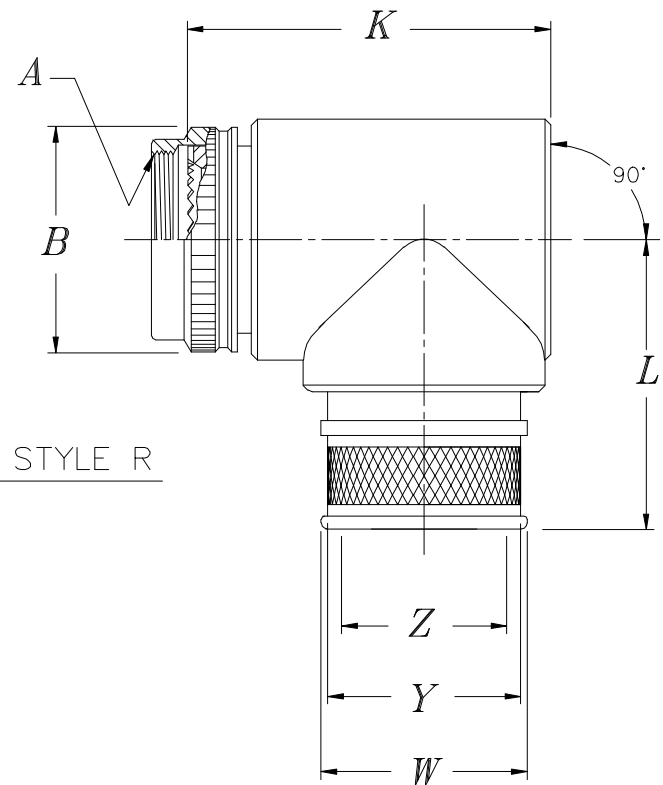

STYLE R

* THIS DOCUMENT INCOMPLETE WITHOUT
 "INTERFACE SPECIFICATION SHEET & SHEET 2"

UNCONTROLLED COPY