

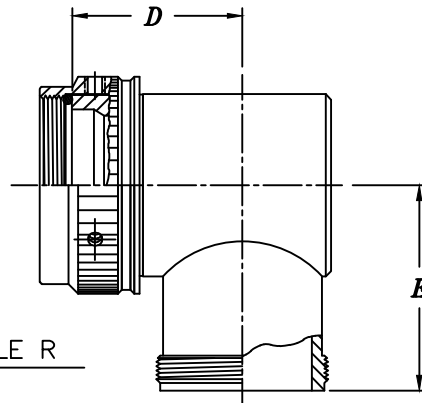

ELECTRO ADAPTER, INC.
 CHATSWORTH, CALIFORNIA, USA 91311
 PHONE: (818) 998-1198
 FAX: (818) 709-5773
 WEB SITE: www.electro-adapter.com

**EXTENDER FOR
 MIL-DTL-26482
 SERIES I
 CONNECTORS**

**SPECIFICATION CONTROL DRAWING
 30121**

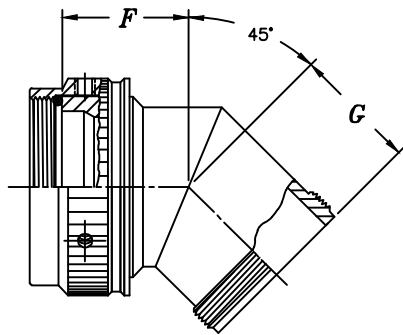
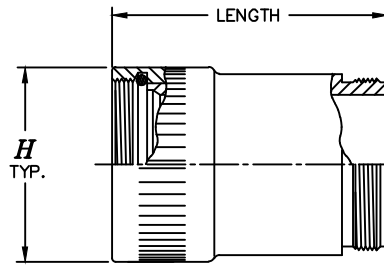
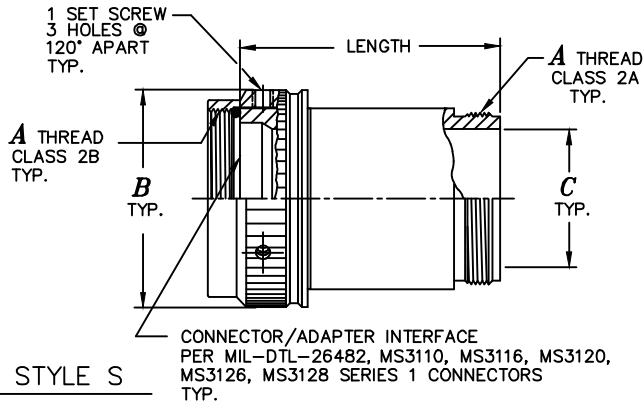

Example Part Number

30121S1408-55

**BASIC
 ADAPTER
 NUMBER**

ADAPTER STYLE
 B = BASIC ADAPTER
 S = STRAIGHT ADAPTER,
 SPIN COUPLING
 A = 45° ADAPTER
 R = 90° ADAPTER

PLATING CODE NUMBER
 55 = CADMIUM, OLIVE DRAB, PER
 SAE AMS-QQ-P-416, TYPE II,
 CLASS 3, OVER ELECTROLESS
 NICKEL PER AMS-C-26074,
 CLASS 3 OR 4, GRADE B
 56 = ELECTROLESS NICKEL PER
 SAE-AMS-2404F
 FOR ADDITIONAL FINISH OPTIONS,
 SEE CATALOG TABLE 4.

ADAPTER DATA									
ORDER NUMBER	SHELL SIZE	A UNIFIED THD. CLASS 2B	B MAX. DIA.	C REF. DIA.	D ±.094	E REF.	F REF.	G REF.	H ±.015 DIA.
0 8	8	.438-28	.781	.312	.562	.875	.591	.578	.562
1 0	10	.562-24	.906	.375	.656	.937	.604	.604	.688
1 2	12	.688-24	1.031	.500	.719	1.000	.629	.629	.812
1 4	14	.812-20	1.156	.625	.781	1.063	.655	.655	.938
1 6	16	.938-20	1.281	.750	.844	1.125	.681	.681	1.062
1 8	18	1.062-18	1.406	.875	.844	1.188	.707	.694	1.188
2 0	20	1.188-18	1.531	1.000	.906	1.250	.733	.720	1.312
2 2	22	1.312-18	1.656	1.125	.969	1.313	.759	.746	1.438
2 4	24	1.438-18	1.781	1.250	1.031	1.375	.785	.772	1.562

LENGTH CODE NUMBER
 SELECT LENGTH IN 1/4" INCREMENTS
 (ie; 08=2.00", 09=2.25", etc.)
 MIN. AVAIL. LENGTH IS 1.00" (04)
 INSERT 00 FOR 45° & 90° ADAPTERS

- NOTES:**
- ASSEMBLY IDENTIFICATION PER MIL-STD-1285.
 - MATERIAL:
 COMPONENTS - ALUMINUM ALLOY
 O'RING - SILICONE

UNCONTROLLED COPY



ELECTRO ADAPTER, INC.
 CHATSWORTH, CALIFORNIA, USA 91311
 PHONE: (818) 998-1198
 FAX: (818) 709-5773
 WEB SITE: www.electro-adapter.com

**EXTENDER FOR
 MIL-DTL-38999
 SERIES III & IV
 CONNECTORS**

**SPECIFICATION CONTROL DRAWING
 30140**

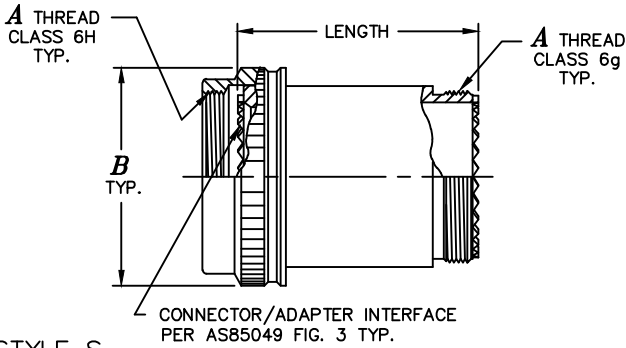

STYLE S

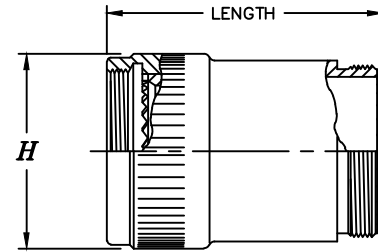

STYLE B

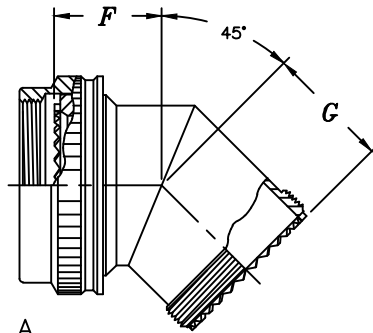

STYLE A

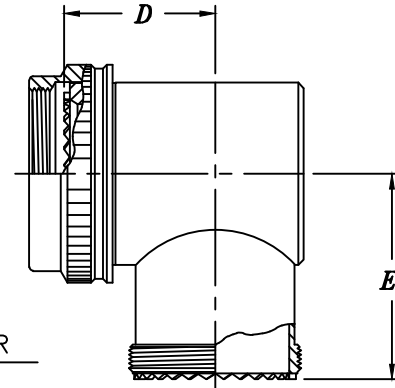

STYLE R

Example Part Number

30140S1408-55

BASIC
ADAPTER
NUMBER

ADAPTER STYLE
 B = BASIC ADAPTER
 S = STRAIGHT ADAPTER,
 SPIN COUPLING
 A = 45° ADAPTER
 R = 90° ADAPTER

PLATING CODE NUMBER
 55 = CADMIUM, OLIVE DRAB, PER
 SAE AMS-QQ-P-416, TYPE II,
 CLASS 3, OVER ELECTROLESS
 NICKEL PER AMS-C-26074,
 CLASS 3 OR 4, GRADE B
 56 = ELECTROLESS NICKEL PER
 SAE-AMS-2404F
 FOR ADDITIONAL FINISH OPTIONS,
 SEE CATALOG TABLE 4.

LENGTH CODE NUMBER
 SELECT LENGTH IN 1/4" INCREMENTS
 (ie; 08=2.00", 09=2.25", etc.)
 MIN. AVAIL. LENGTH IS 1.00" (04)
 INSERT 00 FOR 45° & 90° ADAPTERS

ADAPTER DATA									
ORDER NUMBER	SHELL SIZE SER III & IV	A METRIC THD	B MAX. DIA.	D ±.094	E ±.094	F ±.094	G ±.094	H ±.015 DIA.	
0 8	A 9	M12 X 1.0	.719	.594	.875	.484	.578	.625	
1 0	B 11	M15 X 1.0	.844	.657	.937	.510	.604	.750	
1 2	C 13	M18 X 1.0	.969	.719	1.000	.535	.629	.875	
1 4	D 15	M22 X 1.0	1.094	.782	1.063	.561	.655	1.000	
1 6	E 17	M25 X 1.0	1.219	.844	1.125	.587	.681	1.125	
1 8	F 19	M28 X 1.0	1.344	.875	1.188	.600	.694	1.250	
2 0	G 21	M31 X 1.0	1.469	.938	1.250	.626	.720	1.375	
2 2	H 23	M34 X 1.0	1.594	1.000	1.313	.652	.746	1.500	
2 4	J 25	M37 X 1.0	1.719	1.062	1.375	.678	.772	1.625	

NOTES: UNLESS OTHERWISE SPECIFIED
 1. ASSEMBLY IDENTIFICATION PER MIL-STD-1285.
 2. MATERIAL:
 COMPONENTS - ALUMINUM ALLOY
 O'RING - SILICONE

UNCONTROLLED COPY



ELECTRO ADAPTER, INC.
 CHATSWORTH, CALIFORNIA, USA 91311
 PHONE: (818) 998-1198
 FAX: (818) 709-5773
 WEB SITE: www.electro-adapter.com

**EXTENDER FOR
 MIL-DTL-38999
 SERIES I & II
 CONNECTORS**

SPECIFICATION CONTROL DRAWING

30141

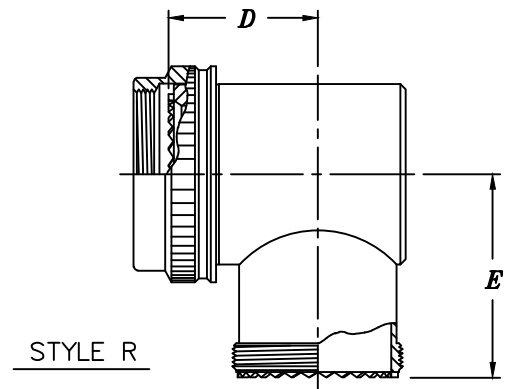
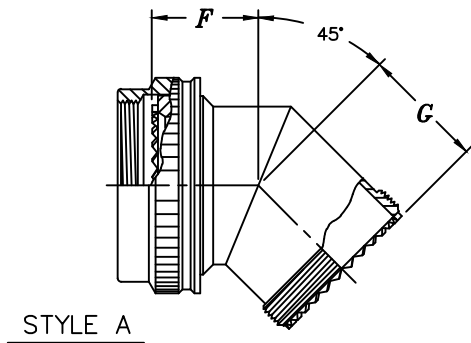
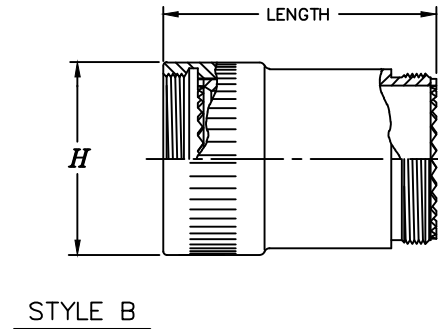
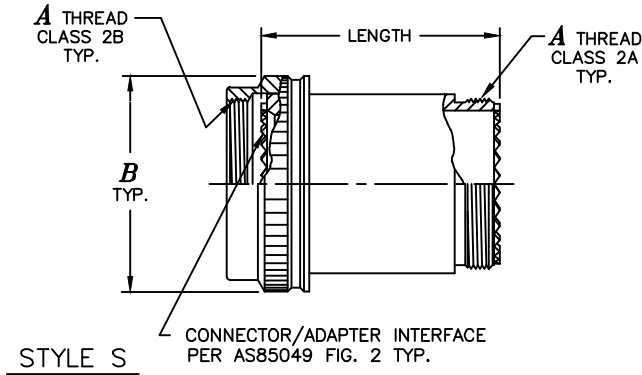

Example Part Number

30141S1408-55

BASIC ADAPTER NUMBER

ADAPTER STYLE
 B = BASIC ADAPTER
 S = STRAIGHT ADAPTER, SPIN COUPLING
 A = 45° ADAPTER
 R = 90° ADAPTER

PLATING CODE NUMBER
 55 = CADMIUM, OLIVE DRAB, PER SAE AMS-QQ-P-416, TYPE II, CLASS 3, OVER ELECTROLESS NICKEL PER AMS-C-26074, CLASS 3 OR 4, GRADE B
 56 = ELECTROLESS NICKEL PER SAE-AMS-2404F
 FOR ADDITIONAL FINISH OPTIONS, SEE CATALOG TABLE 4.

ADAPTER DATA									
ORDER NUMBER	SHELL SIZE		A UNIFIED THD.	B MAX. DIA.	D ±.094	E ±.094	F ±.094	G ±.094	H ±.015 DIA.
	SER. II	SER. I							
0 8	8	9	.438-28	.719	.594	.875	.484	.578	.562
1 0	10	11	.562-24	.844	.657	.937	.510	.604	.688
1 2	12	13	.688-24	.969	.719	1.000	.535	.629	.812
1 4	14	15	.812-20	1.094	.782	1.063	.561	.655	.938
1 6	16	17	.938-20	1.219	.844	1.125	.587	.681	1.062
1 8	18	19	1.062-18	1.344	.875	1.188	.600	.694	1.188
2 0	20	21	1.188-18	1.469	.938	1.250	.626	.720	1.312
2 2	22	23	1.312-18	1.594	1.000	1.313	.652	.746	1.438
2 4	24	25	1.438-18	1.719	1.062	1.375	.678	.772	1.562

LENGTH CODE NUMBER
 SELECT LENGTH IN 1/4" INCREMENTS (ie; 08=2.00", 09=2.25", etc.)
 MIN. AVAIL. LENGTH IS 1.00" (04)
 INSERT 00 FOR 45° & 90° ADAPTERS

NOTES: UNLESS OTHERWISE SPECIFIED
 1. ASSEMBLY IDENTIFICATION PER MIL-STD-1285.
 2. MATERIAL:
 COMPONENTS - ALUMINUM ALLOY
 O'RING - SILICONE

UNCONTROLLED COPY



ELECTRO ADAPTER, INC.
 CHATSWORTH, CALIFORNIA, USA 91311
 PHONE: (818) 998-1198
 FAX: (818) 709-5773
 WEB SITE: www.electro-adapter.com

**EXTENDER FOR
 MIL-DTL-5015,
 MIL-DTL-26482 SERIES II
 CONNECTORS**

**SPECIFICATION CONTROL DRAWING
 30154**

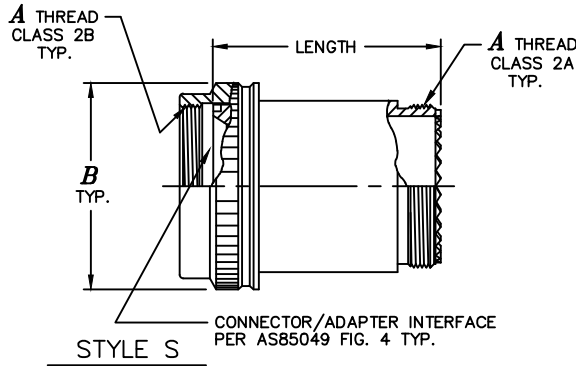

STYLE S

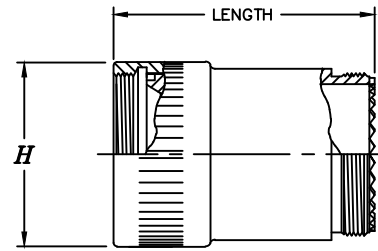

STYLE B

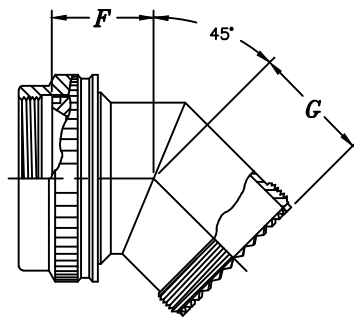

STYLE A

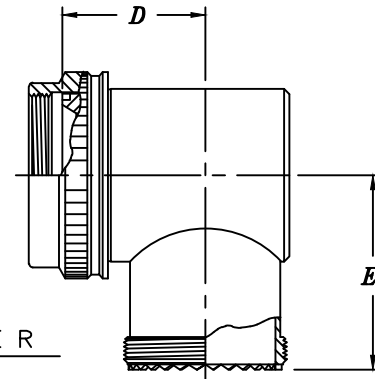

STYLE R

Example Part Number

30154S1408-55

BASIC ADAPTER NUMBER

ADAPTER STYLE
 B = BASIC ADAPTER
 S = STRAIGHT ADAPTER, SPIN COUPLING
 A = 45° ADAPTER
 R = 90° ADAPTER

PLATING CODE NUMBER
 55 = CADMIUM, OLIVE DRAB, PER SAE AMS-QQ-P-416, TYPE II, CLASS 3, OVER ELECTROLESS NICKEL PER AMS-C-26074, CLASS 3 OR 4, GRADE B
 56 = ELECTROLESS NICKEL PER SAE-AMS-2404F
 FOR ADDITIONAL FINISH OPTIONS, SEE CATALOG TABLE 4.

LENGTH CODE NUMBER
 SELECT LENGTH IN 1/4" INCREMENTS (ie; 08=2.00", 09=2.25", etc.)
 MIN. AVAIL. LENGTH IS 1.00" (04)
 INSERT 00 FOR 45° & 90° ADAPTERS

ADAPTER DATA								
ORDER NUMBER	SHELL SIZE	A UNIFIED THD.	B ±.020 DIA.	D ±.094	E ±.094	F ±.094	G ±.094	H ±.015 DIA.
0 8	8	.500-20	.607	.594	.875	.516	.578	.625
1 0	10	.625-24	.724	.657	.937	.542	.604	.750
1 2	12	.750-20	.848	.719	1.000	.567	.629	.875
1 4	14	.875-20	.974	.750	1.063	.580	.655	1.000
1 6	16	1.000-20	1.102	.812	1.125	.606	.681	1.125
1 8	18	1.062-18	1.208	.844	1.188	.619	.694	1.188
2 0	20	1.188-18	1.335	.907	1.250	.645	.720	1.312
2 2	22	1.312-18	1.458	.969	1.313	.671	.746	1.438
2 4	24	1.438-18	1.583	1.032	1.375	.697	.772	1.562

NOTES: UNLESS OTHERWISE SPECIFIED
 1. ASSEMBLY IDENTIFICATION PER MIL-STD-1285.
 2. MATERIAL: COMPONENTS - ALUMINUM ALLOY

UNCONTROLLED COPY