



ELECTRO ADAPTER INC.
 CHATSWORTH, CALIFORNIA, USA 91311
 PHONE (818) 998-1198
 FAX (818) 709-5773

SECTION 2 - MAGNEFORM TERMINATION
SHRINK BOOT, STRAIN RELIEF,
EMI/RFI, SHIELD SOCK
SAE AS85049 CATEGORY 3B

E * * 11

SHEET 1 OF 2

Table 2 - Cable Entry Data

ENTRY ORDER NUMBER	Y ±.015 DIA.	Z ±.010 DIA.	ENTRY ORDER NUMBER	Y ±.015 DIA.	Z ±.010 DIA.
03	.281	.188	17	1.156	1.062
04	.344	.250	18	1.219	1.125
05	.406	.312	19	1.281	1.188
06	.469	.375	20	1.344	1.250
07	.531	.438	21	1.406	1.312
08	.594	.500	22	1.469	1.375
09	.656	.562	23	1.531	1.438
10	.719	.625	24	1.594	1.500
11	.781	.688	25	1.656	1.562
12	.844	.750	26	1.719	1.625
13	.906	.812	27	1.781	1.688
14	.969	.875	28	1.844	1.750
15	1.031	.938	29	1.906	1.812
16	1.094	1.000	30	1.969	1.875

Table 3 - Length Code Data

CONN CODE NUMBER	L MAX
18	1.250
21	1.250
32	1.750
40	1.250
41	1.250
54	1.250
61	1.500
76	1.250

WHEN MAXIMUM CABLE ENTRY EXCEEDS THE CONNECTOR INTERFACE DIAMETER, A 2 PIECE ADAPTER WILL BE SUPPLIED. ENTRY SIZES. CONSULT FACTORY FOR LARGER

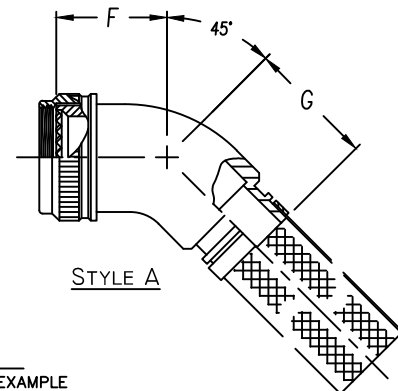
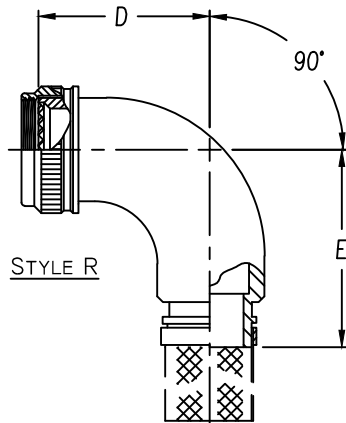
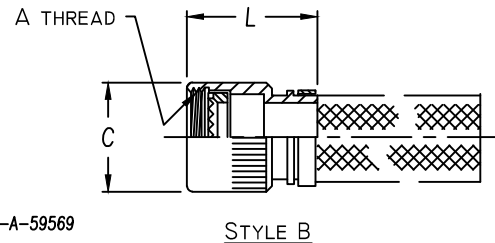
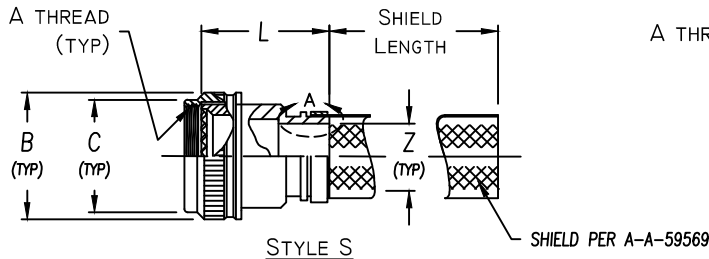

ASSEMBLY PART NUMBER

TO ESTABLISH YOUR P/N, USE THE FOLLOWING EXAMPLE

E 4 1 1 1 S 2 3 0 8 2 0 6 B 5 1

FUNCTION DESIGNATOR
 A-NON EMI ADAPTER

CONNECTOR CODE NUMBER - TABLE 1 ⑥

SERIES PART NUMBER

ADAPTER STYLE
 S = STRAIGHT SPIN COUPLING ADAPTER
 B = STRAIGHT BASIC ADAPTER
 R = 90° ADAPTER
 A = 45° ADAPTER

ACCESSORY ORDER NUMBER-TABLE 1

CABLE ENTRY DATA - TABLE 2

MOD CODE ⑥

PLATING CODE NUMBER-TABLE 4 ⑥

GLAND & O'RING MATERIAL OPTION
 B - NEOPRENE & BUNA-N
 S - SILICONE
 N - NONE REQUIRED (NON ENVIROMENTAL)

SHIELD LENGTH CODE
 SHIELD LENGTHS CHOSEN IN 1.00 INCH INCREMENTS
 (I.E. 08 = 8.00"). MIN LENGTH IS 3.00" CODE 03,
 MAX LENGTH IS 200" CODE 200(00 FOR NO SHIELD)

SHIELD OPTION
 1 - SINGLE LAYER TINNED COPPER
 2 - DOUBLE LAYER TINNED COPPER
 3 - SINGLE LAYER SILVER COATED COPPER
 4 - DOUBLE LAYER SILVER COATED COPPER
 5 - ASSY. SUPPLIED WITH DRIVE BAND LESS SHIELD
 0 - NO SHIELDING OR DRIVE BAND REQUIRED.

Table 1 - Order Number Data

E * * 11

SHEET 2 OF 2

Accessory Order Number By Connector Code & Shell Size

ORDER NUMBER	Accessory Order Number By Connector Code & Shell Size										A UNIFIED THREAD	B MAX DIA.	C MAX DIA.	D ±.125 DIM.	E MAX DIM.	F ±.125 DIM.	G MAX DIM.	ORDER NUMBER
	18 ④	21	32 ②	40 ③	41	54	64	61	76	⑦								
01	8S (B)										.375-32	.750	.531					01
03	8S (A)										.438-27	.812	.594					03
04	8S (C)	8			8, 9				8		.438-28	.812	.594	1.125	1.375	.812	1.062	04
05					8 & 8S						.500-20	.875	.656					05
06	10S (-)							8, A			.500-28	.875	.656					06
07				9, A						M12 x 1.0	.719	.656						07
08	10SL (C)	10			10, 11		3		10		.562-24	.844	.719					08
10	10SL(A,B), 12, 12S(B,C)				10, 10S, 10SL			12			.625-24	1.000	.781	1.250	1.500	.875	1.125	10
11								10, B			.625-28	1.000	.781					11
12				11, B						M15 x 1.0	.844	.781						12
13	12 & 12S (A)	12			12, 13				12		.688-24	1.062	.844					13
15	14 & 14S (-)		12		12 & 12S	7	14				.750-20	1.125	.906	1.375	1.625	.938	1.188	15
16				13, C						M18 x 1.0	.969	.906						16
18		14			14, 15				14		.812-20	1.188	.969					18
19	16 & 16S (-)		14		14 & 14S	12	16				.875-20	1.250	1.031	1.500	1.750	1.000	1.250	19
20								14, D			.875-28	1.250	1.031					20
21				15, D						M22 x 1.0	1.094	1.031						21
23		16			16, 17				16		.938-20	1.312	1.094					23
24	18 (-)		16		16 & 16S	19	18				1.000-20	1.375	1.156	1.625	1.875	1.062	1.312	24
25								16, E			1.000-28	1.375	1.156					25
26				17, E						M25 x 1.0	1.219	1.156						26
28		18			18, 19	18	27		18		1.062-18	1.438	1.219					28
29	20 (-)		18						20		1.125-18	1.500	1.281					29
30	20 (R)										1.125-24	1.500	1.281	1.750	2.000	1.094	1.375	30
31								18, F			1.125-28	1.500	1.281					31
32				19, F						M28 x 1.0	1.344	1.281						32
34		20			20, 21	20	37		20		1.188-18	1.562	1.344					34
35	22 (-)		20						22		1.250-18	1.625	1.406	1.875	2.125	1.156	1.406	35
36								20, G			1.250-28	1.625	1.406					36
37				21, G						M31 x 1.0	1.469	1.406						37
39		22			22, 23	22			22		1.312-18	1.688	1.469					39
40	24 (-)		22						24		1.375-18	1.750	1.531	2.000	2.250	1.188	1.438	40
41								22, H			1.375-28	1.750	1.531					41
42				23, H						M34 x 1.0	1.594	1.531						42
44		24			24, 25	24			24		1.438-18	1.812	1.594					44
45							61				1.500-18	1.875	1.656					45
46								24, J			1.500-28	1.875	1.656	2.125	2.375	1.250	1.500	46
47				25, J						M37 x 1.0	1.719	1.656						47
48											1.562-18	1.938	1.719					48
49	28 (-)		24						28		1.625-18	2.000	1.781	2.375	2.625	1.344	1.625	49
51						28					1.750-18	2.125	1.906					51
52	32 (B,C)		28						32		1.875-16	2.250	2.031					52
53	32 (A,R)										1.906-18	2.281	2.062	2.625	2.875	1.438	1.688	53
54						32					2.000-18	2.375	2.156					54
55	36 (B)		32						36		2.062-16	2.469	2.219					55
56	36 (R)										2.062-24	2.469	2.219					56
57	36 (C)										2.125-16	2.500	2.281	2.875	3.125	1.562	1.812	57
58	36 (A)										2.125-18	2.500	2.281					58
59						36					2.250-16	2.625	2.406					59
60	40 (B)		36						40		2.312-16	2.719	2.469					60
61	40 (A,C)										2.375-16	2.750	2.531	3.125	3.375	1.688	1.938	61
62						40					2.500-16	2.875	2.656					62

NOTES: UNLESS OTHERWISE SPECIFIED.

1 THREADS ARE RIGHT HAND IN ACCORDANCE WITH FED-STD-H28, CLASS 2B.

② THREADS NOTED ARE LEFT HAND, CLASS 2B.

③ THREADS NOTED ARE ISO METRIC, CLASS 6H.

④ CODE 18 SHELL SIZES ARE FOLLOWED IN PARENTHESIS BY CONNECTOR MFR CODE. SEE CONNECTOR CODE 18 CHART AT RIGHT & EXAMPLE PART NUMBER FOR DETAILS.

5 TABLE 1 LISTS THE MOST USED CONNECTOR CODES. SEE SECTION 11 FOR OTHER CODES AVAILABLE AND COMPLETE CONNECTOR PART NUMBER CROSS REFERENCE.

⑥ SEE SUPPORT DATA SECTION FOR PLATING AND MODIFICATION CODE OPTIONS.

⑦ ADD .25 TO "D" & "F" FOR CONNECTOR CODES 30, 32 & 61.

⑧ SEE SUPPORT DATA SECTION FOR TABLE V & AVAILABLE STYLES

④ Connector Code 18 Chart

CONNECTOR CODE	CONNECTOR MANUFACTURER (MS3100, MS3101, MS3106 & MS3107)
A	AMPHENOL, CLASS A
B	BENDIX, CLASS A, E & R
C	CANNON, CLASS A, E & R
D	MFR. UNKNOWN, CLASS A, E & R
R	AMPHENOL, CLASS R
-	MFR. CODE NOT REQUIRED