



ELECTRO ADAPTER INC.
 CHATSWORTH, CALIFORNIA, USA 91311
 PHONE (818) 998-1198
 FAX (818) 709-5773

**SECTION 2 - BANDING TERMINATION
 WIRE HARNESS ACCESSORIES,
 ELECTRICAL, EMI / RFI / EMP,
 SHIELD SPLICE KIT**

900-859

SHEET 1 OF 1

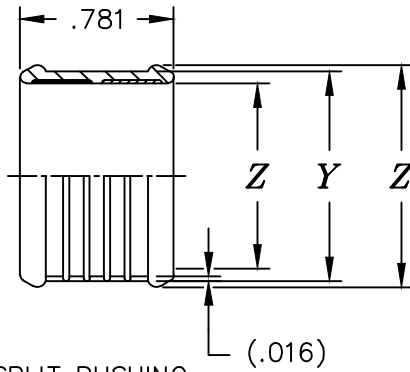
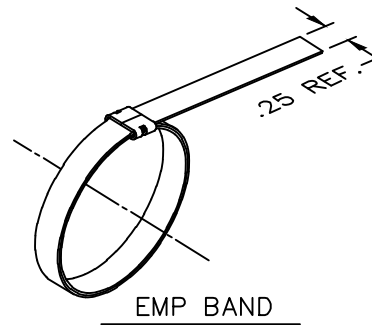
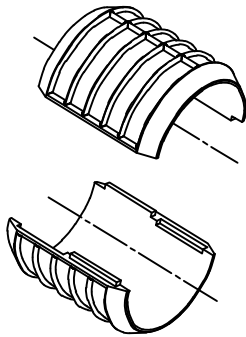

SPLIT BUSHING

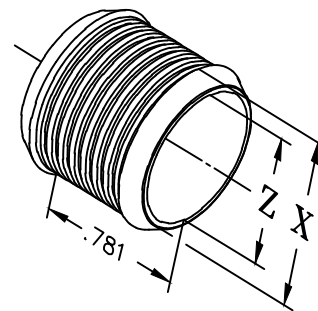

SOLID BUSHING

Example Part Number

900-859-160055B

BASIC BUSHING NUMBER

BUSHING DATA			
ORDER NUMBER	Z ±.015 DIA.	Y ±.015 DIA.	X ±.015 DIA.
0 3	.188	.288	.312
0 4	.250	.350	.375
0 6	.375	.475	.500
0 8	.500	.600	.625
1 0	.625	.725	.750
1 2	.750	.850	.875
1 4	.875	.975	1.000
1 6	1.000	1.100	1.125
1 8	1.125	1.225	1.250
2 0	1.250	1.350	1.375

CONFIG.
 00 = SOLID BUSHING
 01 = SPLIT BUSHING
 02 = SOLID BUSHING W/SHRINK SLEEVE
 03 = SPLIT BUSHING W/SHRINK SLEEVE

MODIFICATION CODE
 B = BUSHING w/ 1/4" EMP BAND (REF. 214L0002)
 OMIT FOR BUSHING ONLY

PLATING CODE NUMBER
 55 = CADMIUM, OLIVE DRAB, PER SAE AMS-QQ-P-416, TYPE II, CLASS 3 OVER ELECTROLESS NICKEL PER AMS-C-26074, CLASS 3 OR 4, GRADE B
 56 = ELECTROLESS NICKEL PER SAE-AMS-2404F, WITH IRIDITE CONVERSION
 FOR ADDITIONAL FINISH OPTIONS, SEE CATALOG TABLE 4.

NOTES:

- ASSEMBLY IDENTIFICATION PER MIL-STD-1285
- MATERIAL:
 BUSHING - ALUMINUM ALLOY
 BAND - 300 SERIES STAINLESS STEEL
- FINISH:
 BAND - PASSIVATE PER SAE AMS-QQ-P-35