

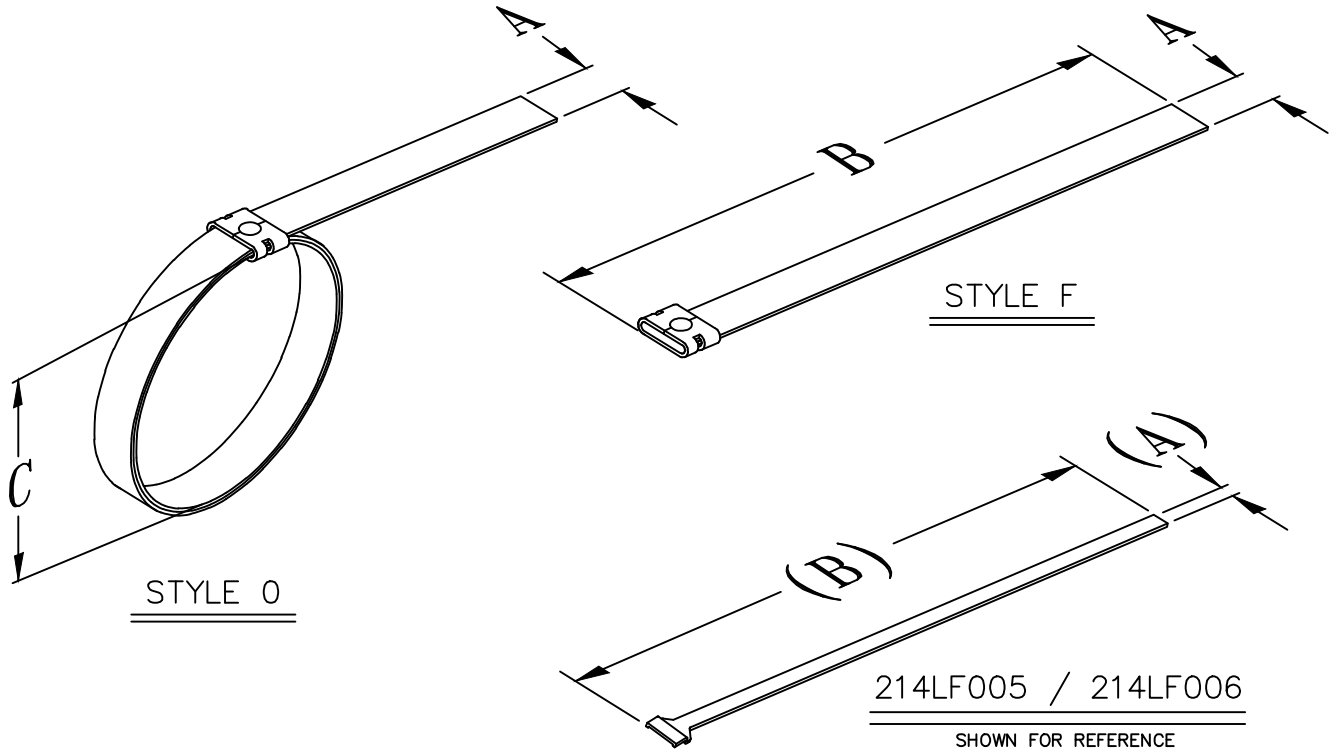

ELECTRO ADAPTER INC.
 CHATSWORTH, CALIFORNIA, USA 91311
 PHONE (818) 998-1198
 FAX (818) 709-5773

**SECTION 2 - BANDING TERMINATION
 WIRE HARNESS ACCESSORIES,
 ELECTRICAL, EMI / RFI / EMP,
 SHIELD TERMINATION BANF**

214L
 SHEET 1 OF 1



Example Part Number

214LF002

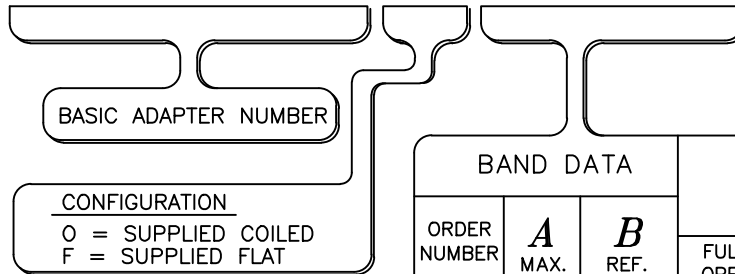

ORDER NUMBER	BAND DATA		ØC APPROX.	
	A MAX.	B REF.	FULL OPEN	MIN. INSTALLED
002	.25	12.00	1.50	.156
003	.25	15.00	2.00	.156
5 005	.12	8.125	.88	.125
6 006	.25	14.25	1.80	.156

NOTES: UNLESS OTHERWISE SPECIFIED

1. ASSEMBLY IDENT. PER MIL-STD-1285
2. MATERIAL: 300 SERIES STAINLESS STEEL
3. FINISH: PASSIVATE PER SAE AMS-QQ-P-35
4. BANDS MUST BE DOUBLE WRAPPED.
5. INSTALL USING BAND-IT® TOOL #A30199
6. INSTALL USING BAND-IT® TOOL #A40199
6. BAND(S) COME BAGGED AND TAG IN QTY(S) FROM 1 TO 100
7. PRODUCT(S) MAY LOOK DIFFERENT THEN SHOWN